

AGA KHAN DEVELOPMENT NETWORK  
QUTB SHAHI HERITAGE PARK  
CONSERVATION & LANDSCAPE RESTORATION

2017-18  
ANNUAL REPORT

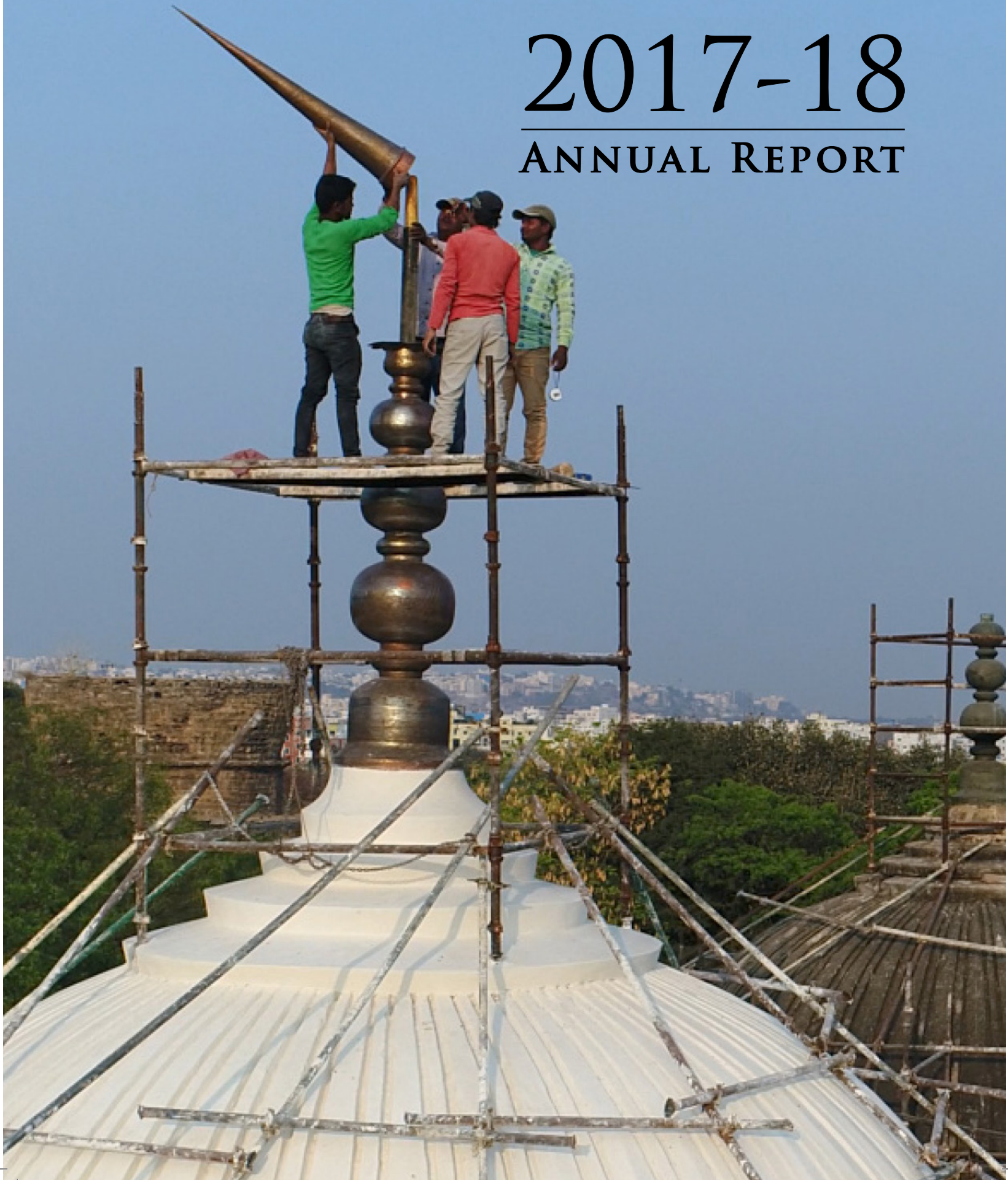





# Qutb Shahi Heritage Park

## Conservation & Landscape Restoration

The Qutb Shahi Heritage Park, is one of the most significant historic medieval necropolises anywhere in the world, comprising over 80 structures including mausoleums, mosques, step-wells/ water structures, a hamaam, pavilions, garden structures – all built during the reign of the Qutb Shahi dynasty.

Major conservation and landscape restoration works are being implemented here since 2013 by the Aga Khan Trust for Culture in partnership with Heritage Telangana, Government of Telangana. Conservation works on 10 monuments are supported by the Tata Trusts.

### Partner Agencies



HERITAGE TELANGANA  
GOVT. OF TELANGANA



QULI QUTUB SHAH URBAN  
DEVELOPMENT AUTHORITY,  
HYDERABAD



AGA KHAN TRUST FOR CULTURE

### Supported by

## TATA TRUSTS

FOR CONSERVATION WORKS  
ON TEN MAJOR MONUMENTS



US AMBASSADOR'S FUND  
FOR CULTURAL PRESERVATION



Embassy  
of the Federal Republic of Germany  
New Delhi

### PHASE 1

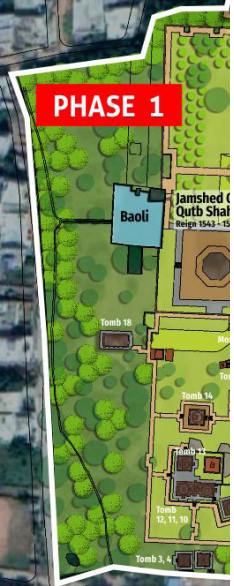

# Pha

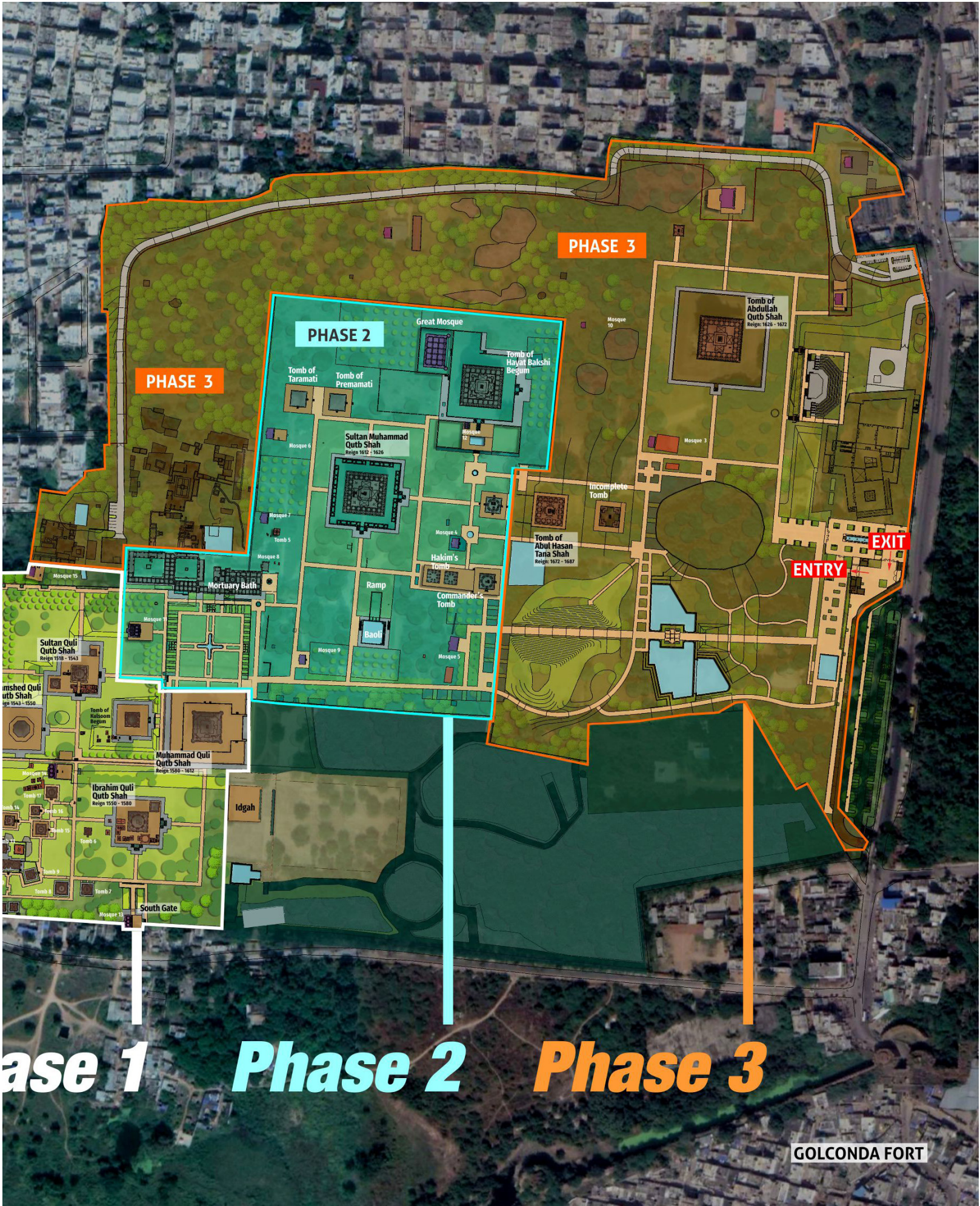

For regular updates on the project, please visit:



<https://www.facebook.com/QutbShahiHeritagePark>



<https://www.instagram.com/qutbshahiheritage>



<https://www.instagram.com/qutbshahiheritage>

**(Cover Page)** *Installation of finial on the western dome of the twin mausoleums of Hakims'*

# Contents

## CONSERVATION

Sultan Quli Qutb Shah's Mausoleum-Garden	14
Muhammad Quli Qutb Shah's Mausoleum-Garden	18
Ibrahim Quli Qutb Shah's Mausoleum	24
Kulsum Begum's Mausoleum	30
Commander's Mausoleum	35
Hakims' Mausoleum	42
Muhammad Qutb Shah's Mausoleum	51
Hayat Bakshi Begum's Mausoleum	57
Baoli to the south east of Ibrahim Quli Qutb Shah's mausoleum	62
Baoli to the west of Jamshed Quli Qutb Shah mausoleum	64
Baoli to the North of Sultan Quli's mausoleum	66
Hayat Bakshi Begum's Mosque	68
Hamam: Serai	70
Mausoleum No. 07*	74
Mausoleum No. 08*	76
Chaukhandi	78
Southern Gateway	81
Mosque above Southern Gateway	83

## Landscape Restoration 86

Garden enclosure of Sultan Quli Qutb Shah's mausoleum	
Garden enclosure of Ibrahim Quli Qutb Shah's mausoleum	
Forecourt of Muhammad Quli Qutb Shah's mausoleum	
Ecological zone to the west of Jamshed Quli Qutb Shah's mausoleum	
Ecological zone to the east of Idgah	

## Plantation 92

## Swadesh Darshan 93

## Paigah Tombs 96

## Badshahi Ashoorkhana 100

## Project Learnings 103

## *Project Team 108*

\*The nomenclature for these buildings are based on the inventory document prepared by the project team.

# Qutb Shahi Heritage Park

## Landscape Masterplan

The landscape plan, developed by Shaheer Associates, appropriately utilizes the space of the presently segregated 'Deccan Park' as a generously proportioned entrance zone hence establishing an effective presence on the public road, and avoiding the present anomaly of the indirect approach that does not encourage an even spread of visitor activity across the complex. Judicious modification and re-organisation of entrances and paths will increase accessibility of the older parts of the complex and allow visitors to easily traverse the whole site and understand its sequential development rather than restrict their experience to only a part. A path system based on the history of the place would play a vital role in enriching the visitors' experience of this large, deep and complex historical site.

### CREATING A BIODIVERSITY ZONE

The northern and southern sections of the Qutb Shahi Heritage Park are to be developed as ecological zones with dense native vegetation. Towards this objective, since 2014 a mapping of all trees has been carried out, and new plantations are being done in a planned manner.



### HERITAGE CONSERVATION

Emergency structural repairs and conservation of 25 major monuments standing within the south-western corner of the 106 acre Qutb Shahi Heritage Park was undertaken during the Phase 1.



Baoli near Sultan Jamshed's Tomb



Sultan Jamshed's Tomb



Sultan Quli Qutb's Tomb

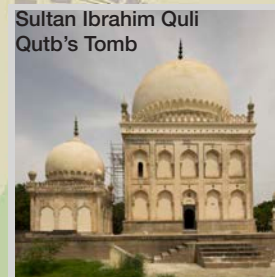

Sultan Ibrahim Quli Qutb's Tomb

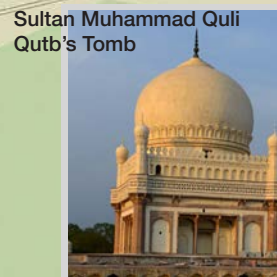

Sultan Muhammad Quli Qutb's Tomb





### ARCHAEOLOGICAL EXCAVATIONS & DISCOVERIES

### REVIVAL OF TRADITIONAL CRAFTSMANSHIP

The project follows a craft-led approach for conservation rather than the usual engineer led approach followed in India over the last century. It is estimated at least 300,000 man-days of work will be generated for craftsmen as a result of the project. This has led to a revival of traditional building crafts and materials in conservation.

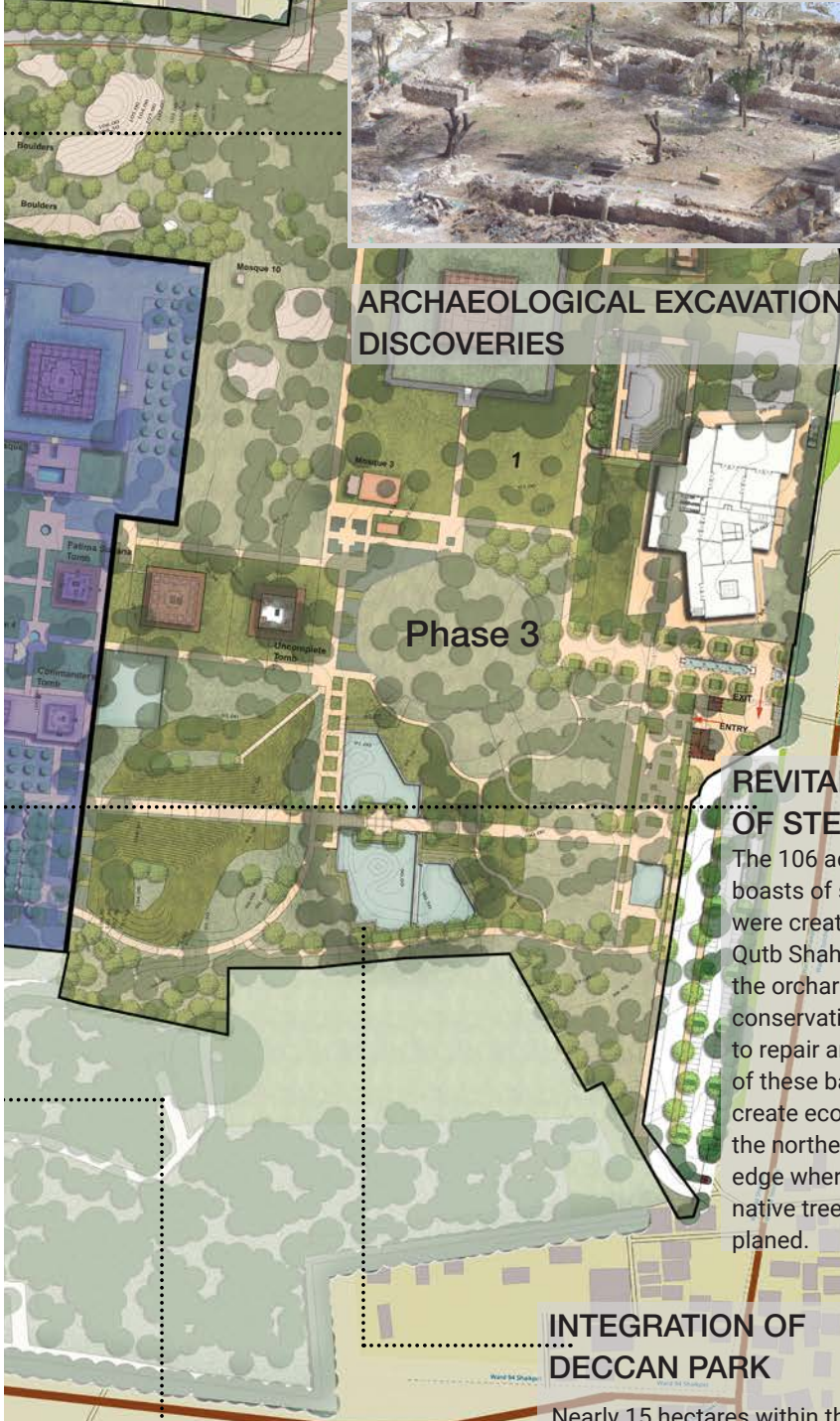

### REVITALIZATION OF STEP-WELLS

The 106 acre Heritage Park boasts of seven baolis that were created here by the Qutb Shahi rulers to irrigate the orchards. The ongoing conservation effort aims to repair and revive each of these baolis as well as create ecological zones on the northern and southern edge where over 10000 native trees are to be planted.

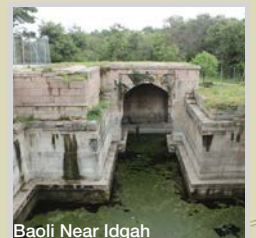
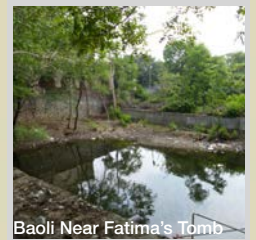
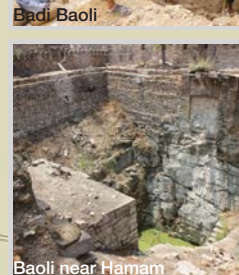

### INTEGRATION OF DECCAN PARK

Nearly 15 hectares within the northern and southern parts of the Qutb Shahi tombs can be potentially converted into an ecological zone by introducing appropriate tree species and enhancing bird habitat unique to the region. Similarly, to the east, the Deccan Park is seen as the ideal entrance zone to the grand complex thereby creating a suitable entry point to the heritage zones wrapped by ecological and formal landscapes.

View of the Qutb Shahi Heritage Park



Qutb Shahi Idgah

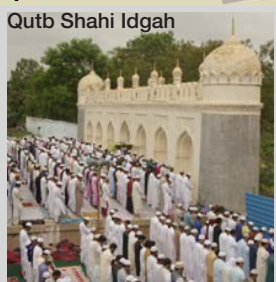



(Above) His Highness the Aga Khan reviewing conservation works at Sultan Quli Qutb Shah's mausoleum. Seen with him are Mr. B Venkatesham (IAS, Secretary, YAT&C, Government of Telangana), Ms. Sunita Bhagwat (IFS, Commissioner of Tourism, Government of Telangana), and Mr. Luis Monreal (General Manager, AKTC)

(Below) On 3<sup>rd</sup> January 2017, Sri K.T.Rama Rao, Hon'ble Minister for Municipal Administration & Urban Development, Government of Telangana, opened the Badi Baoli to the public – three years after its collapse. Janaab Kausar Mohiuddin, MLA was also present on the occasion, along with other delegates.

## Completion of Phase 1 of Works at Qutb Shahi Heritage Park

**On 18 April 2018, Heritage Telangana, Government of Telangana and Aga Khan Trust for Culture celebrated the WORLD HERITAGE DAY with a ceremony marking the completion of conservation works on 25 monuments and landscape restoration over a 20 acre zone in the Qutb Shahi Heritage Park. This came after four years of painstaking conservation works, supported by the TATA Trusts, wherein master-craftsmen clocked 150,000 man-days of work to restore structural stability and grandeur of the Qutb Shahi monuments.**

Emergency structural repairs and conservation of 25 major monuments standing within the south-western corner of the 106 acre Qutb Shahi Heritage Park have now been completed. Thus conservation works on the mausoleums of Sultan Quli Qutb Shah, Subhaan Quli Qutb Shah, Jamshed Quli Qutb Shah, Muhammad Quli Qutb Shah, Kulsum Begum have been completed as well as on the Hamam, three Baolis, several smaller mausoleum and grave mosques, the Idgah, grave platforms, amongst other structures.

Conservation works have consistently commenced with structural repairs, stitching of cracks, restoring missing stone elements and have included removal of inappropriate modern materials such as 20<sup>th</sup> century cement concrete and restoration of authentic lime mortar – as used by the 16th century builders. In the process hidden ornamentation have been revealed and restored, the original architectural character restored and long term preservation ensured. The massive platforms have been laid with granite blocks – to prevent water seepage into the foundations. Each structure, grand or tiny has received the same attention by conservators and craftsmen.

Significantly, archaeological excavations have revealed extent of enclosed gardens and the 16th century landscapes have been restored, further enhancing the historic character. Grading of earth has also revealed buried elements, water drainage patterns which have been eventually restored, resulting in collection of 3 million litres of water in two baolis each monsoon.

Conservation and landscape works have been peer reviewed by international experts and were preceded by exhaustive documentation, condition assessment, 3D Laser scanning and archival research.

Conservation and landscape works on all 80 monuments standing within the 106 acre Qutb Shahi Heritage Park are expected to be completed, under this partnership project, by AD 2023.



# Phase - I Works

The Conservation works at the Qutb Shahi Heritage Park commenced with a January 2013 MoU between Heritage Telangana and the Aga Khan Trust for Culture. As per the MoU, conservation works are to be undertaken on all 80 monuments that stand within the 106 acre complex. In the first phase of works, emergency repairs such as those on the Badi Baoli and Fatima's Tomb were undertaken as well as conservation works on all monuments that stand within the south-west quadrant of the complex.

Conservation works on each of the 80 monuments undertaken here has aimed at ensuring long term preservation and respecting the intention of the original builders – thus consistently removing cement and other inappropriate materials used in the 20th century & ensuring authenticity of the repairs by matching the 16th century works in all respects

*Conservation works were carried out in a phased manner to ensure only portions of the site are inaccessible to visiting public at any given time.*

Garden Enclosure around Tomb of Sultan Quli Qutb Shah

Tomb of Sultan Quli Qutb Shah  
Reign: 1518 - 1543

Tomb of Subhan Quli Qutb Shah

Tomb of Muhammad Quli Qutb Shah  
Reign: 1580 - 1612

Tomb of Jamshed Quli Qutb Shah  
Reign: 1543 - 1550

Tomb of Kulsum Begum

## 25 Monuments Restored in Phase I

Baoli to the North of the Tomb of Jamshed Quli Qutb Shah

Photograph Courtesy: Col. Horatio Biden  
Tombs at Golconda from The Biden Album, Vol. 1;  
Photo credit: H.J.Nixon c.1860 ; Source: Alkazi Foundation

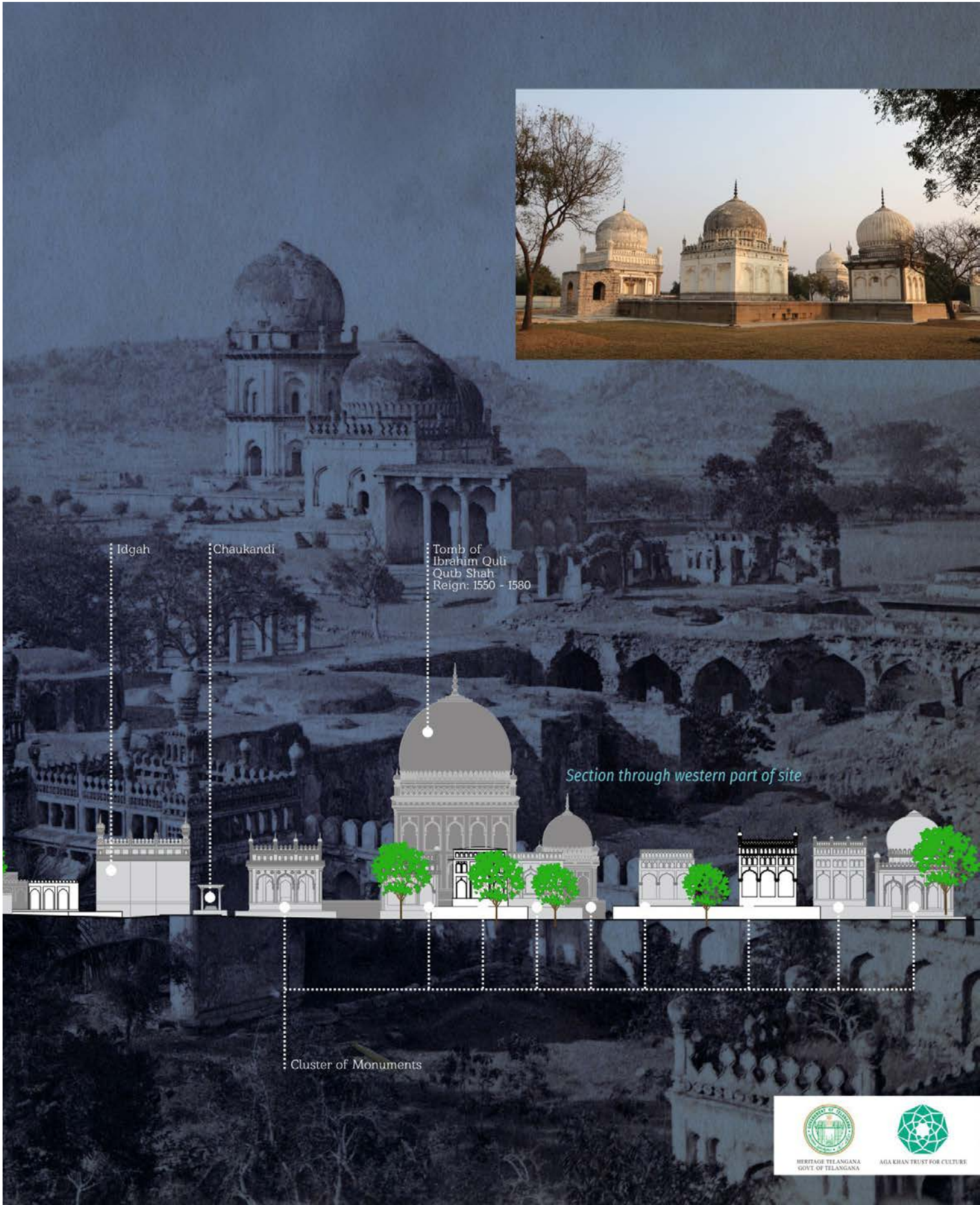

Sultan Quli Qutb Shah's tomb was built in 1543 A.D, during his own lifetime. During a sustained archival research programme, archival images dating from the 1860s were discovered - revealing that the tomb's external surface was originally covered with ornate lime stucco works. The arches were seen to be crowned with medallions the minarets had ribbed plaster patterns and the merlons were studded with highly ornate lime stucco.

Upto 6" thick cement layers were removed from the dome and it was re-plastered with lime.



Remnants of original details found on the merlons were exposed and then restored.

16th century ornamentation restored on the minarets and battlements at the parapet

Mouldings, ornamental bands and pigeon holes were conserved by master-craftsmen

Removal of layers of cement plaster from the facade revealed historic stucco plaster in 2014



Cement concrete flooring on the plinth replaced with 30 mm granite laid on base lime concrete

## HERTIAGE CONSERVATION: MAUSOLEUM OF SULTAN QULI QUTB SHAH

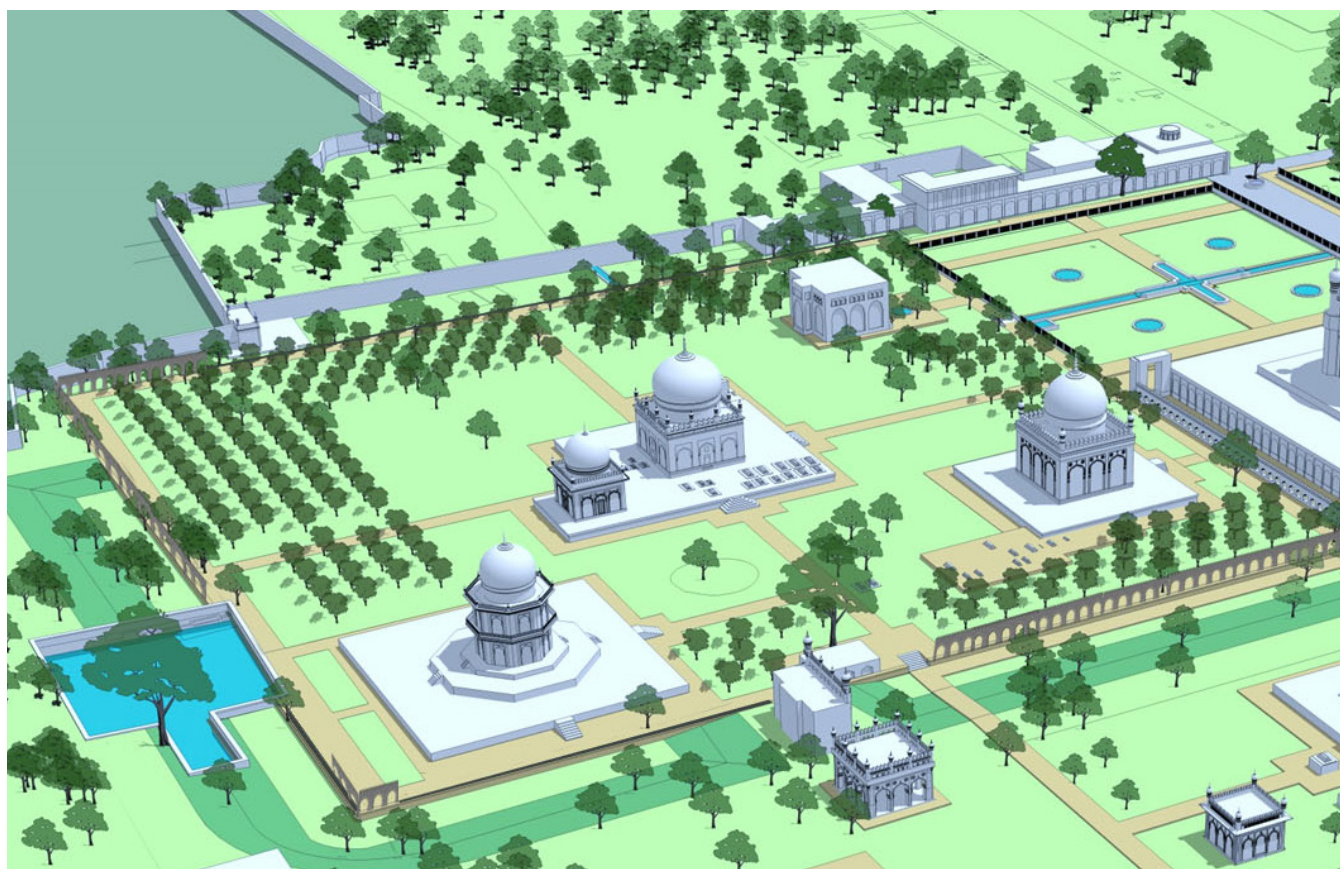

# 01 CONSERVATION & LANDSCAPE OF Sultan Quli Qutb Shah's Tomb - Garden

*(Above) An illustration showing the Tomb-Garden Enclosure of Sultan Quli Qutb Shah*

As part of the conservation efforts at the mausoleum of Sultan Quli Qutb Shah, several layers of cement, which were added later, were carefully removed revealing intricate stucco medallions and arch crowns on the North facade. Similar patterns were found on the arched openings. Discovery of these patterns in-situ allowed a scientific restoration of the patterns where these were missing.

The 16th century enclosure wall made in hand dressed ashlar masonry and spanning nearly 400 meters - with the Mausoleum of Sultan Quli Qutb Shah in centre and surrounding the mausoleums of Jamshed Quli Qutb Shah, Subhan Quli Qutb Shah and Kulsum Begum along with multiple grave platforms.

Based on evidence of a portion of existing arcade on the south-eastern corner of enclosure wall, missing arcade was marked on the wall for construction of arches throughout the length of the wall.



***Action Taken:***

- Remains of the existing enclosure walls were revealed along with the remnants of the gateway on the eastern axial pathway leading towards mausoleum of Sultan Quli Qutb Shah.
- Masonry of the gateway was raised to reinforce the existence of the old gateway.
- Hand chiseled dressed stones on the enclosure wall and top edging band were fixed in missing portions of the enclosure wall. Earth grading was carefully carried out within the expanse of historic enclosure wall enveloping the mausoleum of Sultan Quli Qutb Shah to ensure drainage of surface water away from the monuments.
- Missing arcade over the 16th century enclosure wall on the south, west and north have been reconstructed thus reinstating the sense of enclosure envisaged by the original builders.
- A total of 125 arches have been reconstructed by stone masons in 2017.
- Battlements and ornamental mouldings matching the existing on eastern arcade have been meticulously restored along a major portion of arcade to reinstate the original appearance.
- Hand dressed edging stone and vertical plinth stone lining the enclosure walls in the north-western corner have ensured reconstruction of arches over a span of 140 meters.



***Next Steps:***

Construction of remaining sections of the enclosure wall in the south-eastern corner along with reconstruction of the arcade will be carried out.



*A: Honeycomb brick shuttering for construction of arches;  
 B: Plastering of masonry battlements above reconstructed arcade;  
 C: Reconstruction of battlements in stone masonry*

**Impact:**

Conservation of the enclosure wall along with the erection of arcade has brought a paradigm shift in the manner in which the tomb complex was perceived earlier. This has introduced a sense of enclosure and formality to the tomb gardens which till recently was mistakenly perceived to have been linked with the Mughal's in India.





*Removal of 20<sup>th</sup> century cement layers from the roof of the mausoleum*

*The cement from the roof was replaced with traditional lime mortar*

## 02 CONSERVATION OF Muhammad Quli Qutb Shah's Mausoleum

Muhammad Quli Qutb Shah (1581- 1611), the fourth king of the Qutb Shahi dynasty laid the foundation of Hyderabad. During his reign, the dynasty reached the zenith of its material and cultural life.

Reaching to a total height of 48 m, the magnificent tomb consists of unique features such as the granite pillars, capitals and brackets, which recall the influence of temple architecture. Raised on a vaulted structure which houses the original grave of the Sultan, it marks the beginning of the double terraced tomb construction.

### *Terrace*

In 2017, terrace of mausoleum was found to be covered in 5 inch thick layer of cement concrete and showed evident signs of water ingress along with vegetation growth. Upon removal of 20th century cement concrete, original lime concrete was found in a dilapidated state.

### *Action Taken:*

- Cement concrete was dismantled along with dilapidated lime concrete underneath and site cleared of debris.
- Traditional lime concrete was laid in appropriate slopes to drain rainwater away from the structure.

## *Parapet*

Archival images from 1870's had shown a solitary parapet stone surviving on the western edge of upper plinth. Based on this, a total of 125 granite blocks were hand carved and dressed for installation along the perimeter edge of the structure.

### *Action Taken:*

- Stone edge bands were installed around the edge of stairwell on the north-eastern and south-western corners of terrace to prevent rainwater from damaging the structure.
- 125 hand chiseled parapet stones matching the original in detail were prepared and installed on the perimeter edge manually by traditional stone craftsmen.

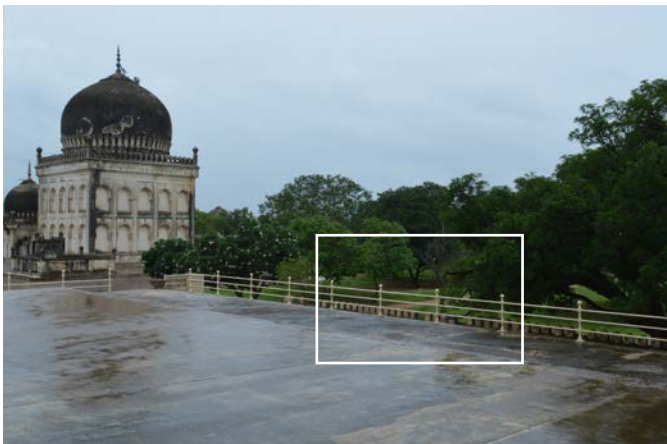
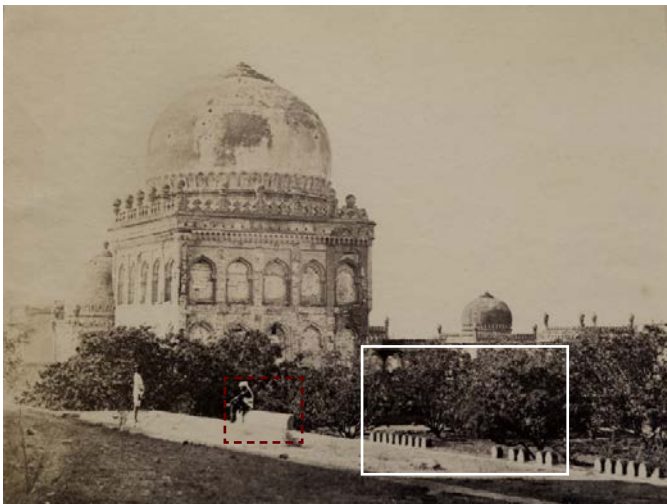

*125 hand chiseled dressed stone blocks with profile matching the archival evidence were installed after removal of the 20<sup>th</sup> century metal railing*



(Left) Removal of excess earth and debris; (Top Right) Lime concreting for installation of flooring; (Bottom Right) 30 mm thick granite stones laid

## *Crypt*

External facade of arcaded crypt was covered with a layer of 20th century cement plaster which had aggravated the water seepage and lack of plinth protection installed around led to capillary rise of ground water. Access steps inside the crypt and leading up to the mausoleum needed repairs and cement lattice screens constructed in 1980's were blocking the flow of light and air inside the crypt arches. These were removed to reinstate the original appearance of the crypt.

### *Action Taken:*

- A stepped platform made of hand-chiseled blocks of granite was installed on the narrow arched stairwell leading to the upper plinth at the north-east corner.
- Hand chiseled granite stone steps and ramp with approved gradient and width for disabled access were installed on the central arched bay on the northern facade to access the crypt.
- Plinth protection in thick granite stone slabs was installed around the structure as depicted in the landscape master plan.
- Cement repairs on the granite steps situated on the south-west corner of the mausoleum were removed and hand-chiseled steps were installed.
- A 60-meter long shallow drain in granite stone slabs was constructed abutting the western facade to drain the rainwater into the subterranean trench drains situated near the south-west corner of the mausoleum.
- Arches along the façade of the crypt on all four sides were repaired structurally using traditional lime mortar and rubble stones after removal of 20th-century cement plaster. Cement plaster on the lower façade was replaced by traditional lime plaster and historic horizontal and vertical bands along with arch crowns discovered during the dismantling of cement plaster were restored by master craftsmen.

- Iron grills of approved design were installed inside crypt arches replacing 20th-century cement lattice screens. This aided in bringing in ambient light and increasing ventilation inside the crypt along with managing visitor access.
- 100 mm thick granite stone edge was installed after repair of low height masonry wall lining the raised platform inside the crypt.
- 30 mm thick granite slab flooring was installed in the crypt to appropriate slope and design to withstand the visitor footfall and make the crypt accessible for visitors.

***Next steps:***

Installation of 45 metal spouts of approved designs to be carried out in the recently installed stone parapet to drain rainwater away from the lower structure.

**Impact:**

Restoration of crypt facade has helped in long term preservation of the monument by removal of 20th-century cement concrete thereby reducing the weight on the monument. Installation of lime concrete on the terrace has stopped the water ingress into the structure, thus prolonging the life of the mausoleum. Reinstatement of hand chiseled stone parapet on the perimeter edge of upper plinth has reinvigorated the original architectural appearance as envisaged by the original builders.



*Conservation works carried out on  
Muhammad Quli Qutb Shah's Mausoleum during 2014-18:*



Dome repairs



Restoring ornamental plasterwork

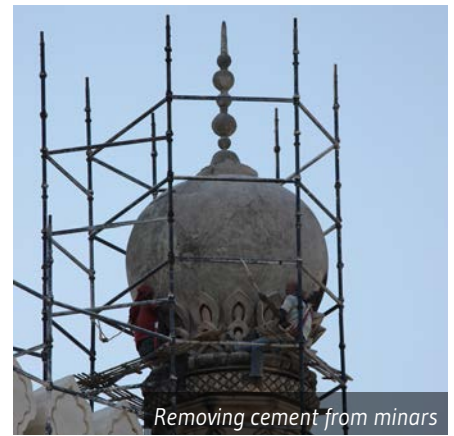

Removing cement from minars



Facade restoration



Conservation of main tomb chamber



Conservation of ceiling medallion



Restoration of original parapet



Granite flooring installed



Modern brick infill removed



Conservation of crypt



Cement replaced with traditional lime plaster



Steps installed to facilitate visitor access

# 03 CONSERVATION OF Ibrahim Quli Qutb Shah's Mausoleum



**BEFORE**



**AFTER**

Restoration of ornamental details on the merlons and band situated below the parapet battlements was carried out based upon in-situ and archival evidence



*Missing and damaged stone elements on facade were restored, including the granite edging around the perimeter of the mausoleum and the black basalt edging on the arched bays.*

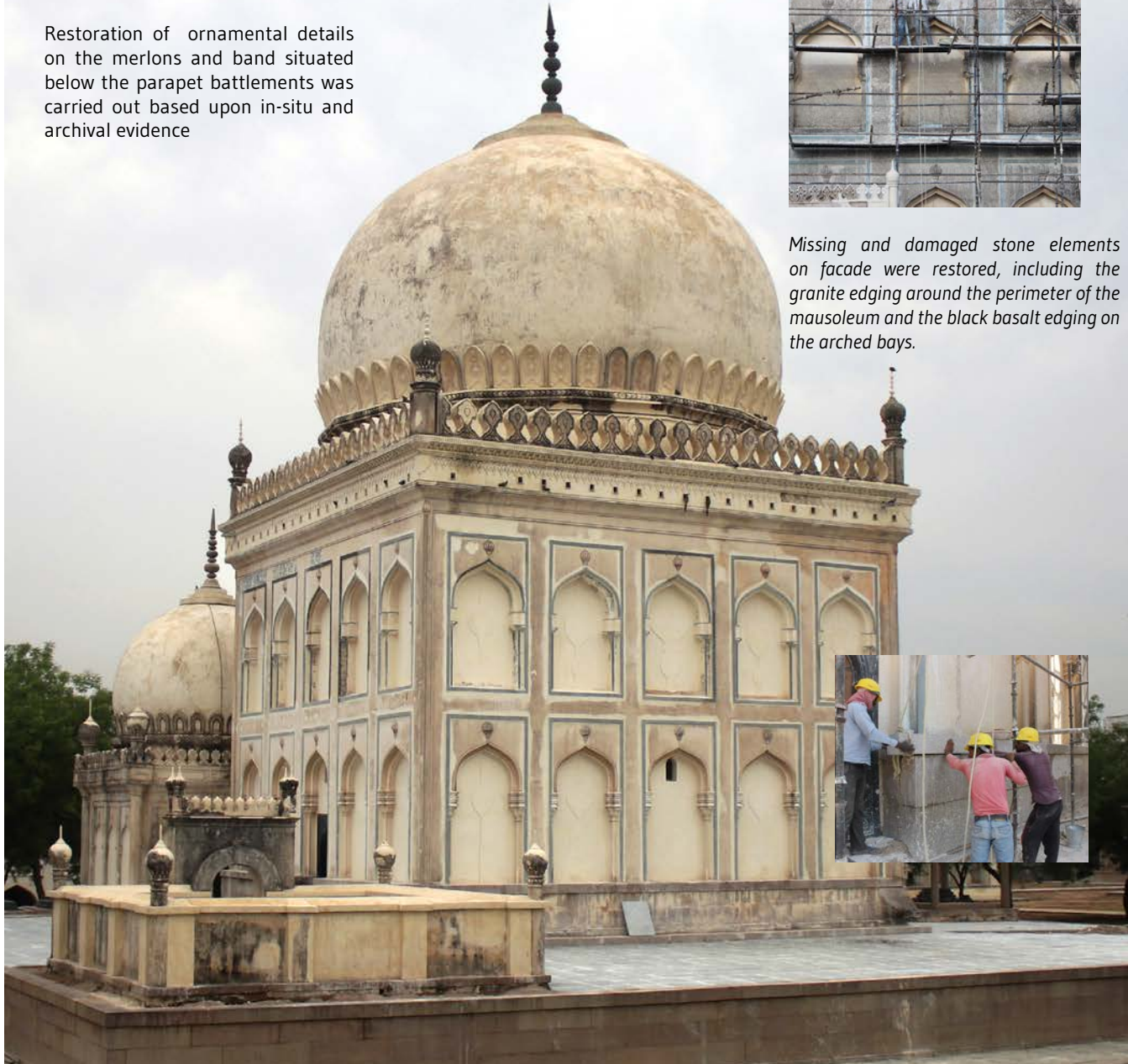



Standing on an accentuated and raised plinth, the bulbous dome structure has two tiers of projected blind arches on its principal facades and traces of enameled tiles, which once embellished the the structure, can still be seen on the southern and eastern facades of the monument. Conservation of internal mausoleum was completed in 2016. All conservation works on the internal surface have been completed including the final layer of lime punning in the repaired and restored portions. Scientific removal of 20<sup>th</sup> century cement and lime wash layers on the external facades was commenced to reveal the distinct stucco patterns in the blind projected arches on all four facades. Multicoloured mosaic tilework was revealed on the upper tier of blind arches on the northern façade. There were evident signs of water ingress resulting in vegetation growth damaging the tiles on the southern and eastern façade. The plinth of the mausoleum was covered with a 2-inch thick layer of cement concrete.



*Architectural documentation of the tile work on the southern facade of the Ibrahim Quli Qutb Shah's Mausoleum*



*Conservation works were preceded by removing cement layers to reveal hidden tiles and stucco work - all of which have been well documented and consolidated to prevent ingress of water*



*Removal of 20<sup>th</sup> century cement concrete layers from the terrace of the mausoleum*



*The cement from the terrace was replaced with traditional lime concrete*

## ***Terrace***

The terrace of the terrace was found covered with vegetation growth causing ingress of water into the monument and resulting in seepage inside the internal dome.

### ***Action Taken:***

- On inspection, the terrace was found to be covered with a thick layer of 20th-century cement concrete and dilapidated lime concrete found below had developed cracks at multiple spots with rainwater seeping through.
- At the onset, vegetation was scientifically removed from the terrace cracks.
- The excess layer of cement concrete, which weighed around 30 tonnes was dismantled and debris cleared from the site.
- Base masonry of parapet walls on all four sides was repaired using rich lime mortar.
- 4 inch thick layer of traditional lime concrete was laid in appropriate slope, followed by continuous compaction and curing using traditional construction technology and techniques.
- Multiple water spouts constructed in granite stones were installed and existing spout on the south-east corner was moved to the eastern side to avoid draining of rainwater from the terrace onto the tilework on southern façade of structure and parapet of the mausoleum of Muhammad Amin situated below.

## Facade

Removal of 20<sup>th</sup> century plaster layers was carried out revealing the obfuscated stucco patterns inside two-tier blind arches along with intricate mosaic tile embellishment on the northern and southern facades.

### Action Taken:

- Based on photographic evidence from the 1860s, the external surface was carefully cleaned of the later added layers to reveal the traces of original glazing and other details on the surface.
- Decorative band below the merlons situated below the dome was restored by master craftsmen using rich lime mortar.
- External drum surface above the terrace and the four corner minarets on parapet have been duly conserved with lime mortar including the restoration of missing details and final layer of lime putty.
- 80 battlements on the parapet wall have been repaired using rich lime mortar and finished with a 1 mm thin layer of lime putty added with organic additives.
- Two-tiered blind arches on the external arches were found to have black basalt stone along the rectangular edge, on the arch mouldings and capital mouldings on the upper tier of the arches. Missing bands in basalt stone around arch mouldings and rectangular frames surrounding the blind arches were installed. Boulders of matching stone were procured from distant sites and stone bands but to size matching the existing evidence at the site.
- Scraping of modern cement and whitewash layers were carried out to reveal hidden tiles on the southern, eastern and northern facades. Open joints of tiles were sealed with rich lime mortar to prevent seepage of rainwater for long term preservation of tile embellishment. A solitary band of red coloured tiles was revealed on the upper tier corner blind arch on the western facade of the mausoleum.
- Evidence of the highly decorative band was found on the surface below the battlements. Details of the band were evident in archival images from the 1860s. The ornate band has been restored on all the four sides and evidence of original design has been left untouched for future interpretation.
- 20th-century plaster layers were carefully removed from the principal facade of the mausoleum to reveal the stucco impressions matching the profiles depicted in 1860's archival images.
- Based on careful investigations and comparative analysis with the archival images, the outline of the missing patterns in the recessed portions of the arches at upper and lower tier were restored in rich lime mortar and finished with lime punning.



(Top) Outline of the missing detail on the facade were restored; (Middle) Missing stone elements added to the external blind arches on the facade; (Bottom) Physical documentation of existing tiles by architects

## *Reinstating the Original Plinth*

The projected plinth was covered with a layer of cement concrete and the dressed stone band on edge of the mausoleum was covered up with a 20th-century brick layer, which was removed in 2016.

### *Action Taken:*

- Missing band on the bottom edge of the mausoleum was reinstated with the installation over 45 hand dressed granite blocks measuring 0.5 m x 0.2 m X 1.0 m. along the perimeter of mausoleum matching the existing evidence at the site.
- The plinth was found to be covered with a 20th century layer of 2-inch thick cement concrete. The layer was dismantled and the site cleared of debris.
- Installation of over 8000 square feet of 30 mm thick granite stone slabs in approved layout and the appropriate slope was carried out to channel rainwater away from the mausoleum.

### **Impact:**

These conservation efforts have in turn helped reveal the character of the structure as intended by the original builders, which were periodically obfuscated by later additions.

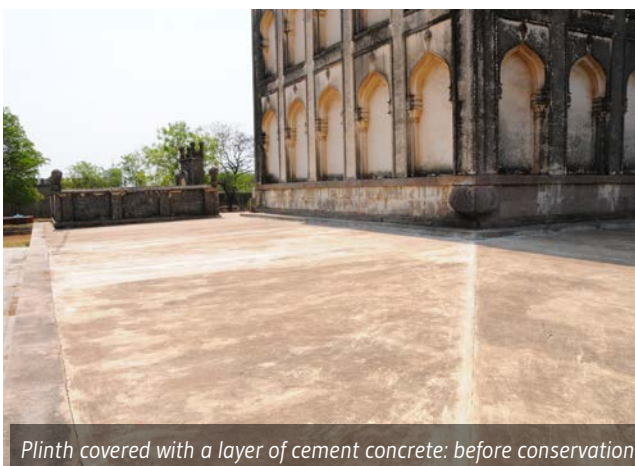

*Conservation works carried out on Ibrahim Quli Qutb Shah's Mausoleum during 2016-2018:*



Removal of damaged and loose plaster layers



Restoring ornamental plasterwork



Final lime punning of internal surface



Restoration of internal surfaces



Outline of original details revealed



Restoration of ceiling medallion



20th century cement removed from plinth



Plinth protection laid



Restoration of facade with lime mortar



*Before Conservation*



*Finishing of principal facades with lime punning*

## 04 CONSERVATION OF Kulsum Begum's Mausoleum

This mausoleum was built during the reign of Mohammed Qutb Shah. Kulsum Begum was the daughter of Muhammad Quli Qutb Shah. Conservation works at this mausoleum included removal of cement plasters, which were a later addition, and restored using traditional lime mortar which was originally used to construct the mausoleum.

## *Dome & Terrace*

The dome nearly 5.5 meters in diameter and 9 meters in height has an approximate area of 320 square meters. It had visible signs of deterioration with cracks on surface permitting water ingress and vegetation growth. Upon closer inspection, the dome was found to be covered with a 3 –inch thick layer of 20th-century cement layer thereby causing the underneath historic lime plaster to disintegrate. The merlons below the dome were partially damaged and ornamental bands above the drum on the terrace were found in a dilapidated condition with vegetation growth augmenting the seepage of rainwater inside the historic lime plaster. The surface of the 16-sided drum was found to be covered with a thin layer of cement mortar. The terrace was covered with a 3-inch thick layer of cement concrete and water spouts were found missing, thereby accentuating the water seepage inside the structure.

### *Action Taken:*

- All cement plaster and loose historic lime plaster layers were meticulously removed from the dome.
- Removal of cement layers revealed holes on dome structure up to 1 meter deep, which would have been made to accommodate wooden scaffolding during 20th-century repairs and later ostensibly covered up without mitigating the ingress of rainwater inside the dome masonry.
- Dome surface was repaired with rich lime mortar and finished with a 1 mm thin layer of lime putty mixed with organic additives.
- 10 craftsmen were employed simultaneously on the dome to complete the plastering and punning to reduce the number of joints to a minimum.
- Merlons situated at the base of the dome was restored with their original profile and details matching the original.
- Ornamental bands situated below the merlons were similarly restored carefully matching the original details in all respects.
- Cement concrete was removed from the terrace and site cleared of debris.
- A 4-inch thick layer of traditional lime concrete was laid in an appropriate slope to drain rainwater away from the structure.
- 4 water spouts made of granite stone projecting 0.45 meters from the parapet were installed below the battlements to channel rainwater from the terrace on to the lower projected plinth of the structure.



*Removal of 6 inch thick cement layer*



*Restoration of ornamental detail*

## *External Surfaces*

The external surface below the dome showed signs of deterioration with evident signs of final finish flaking at multiple spots. Modern repairs carried out using cement had accentuated the dilapidation to the underlying lime mortar. Vegetation growth was also visible on the structure and caused by water seepage on principal facades caused due to missing water spouts on the terrace.

### *Action Taken:*

- All loose mortar, 20<sup>th</sup> century lime wash, and cement layers were carefully dismantled after cleaning of monument manually using brushes and water.
- Corner minarets were repaired and ornamental details were restored using rich lime mortar. Missing finials were prepared as per existing evidence and installed on the minarets.
- The battlements were repaired and restored using traditional lime mortar.
- The intricate flower bands, arch details were restored by master craftsmen with rich lime mortar and traditional tools.
- Plain plastered surfaces below the battlements were repaired with traditional lime mortar and finished with a 1 mm thin layer of lime putty mixed with organic additives.
- Ornamental floral medallions on the tripartite blind arch façade were restored by master craftsmen using rich lime mortar.
- A number of original mouldings and ornamental features on the external facades were obfuscated by addition of modern plaster layers. Cement was meticulously removed to mitigate any unintended damage to the original details. Missing portions were restored matching the existing site evidence.



*Restoration of details*



*Battlements repaired and restored*



*Minars repaired with traditional lime mortar*



## Internal Surface

Internal wall and ceiling surfaces were found to be covered with a half-inch thick layer of modern cement plaster. A prominent section of the ceiling medallion of the octagonal profile chamber was found partially damaged and covered with multiple layers of limewash. Small openings at the terrace levels were open and were causing water ingress coupled with unhindered access to pigeons, thereby aggravating the decay.

### Action Taken:

- Upon investigation of the surface plaster inside the mausoleum, original details covered with cement plaster had altered the original patterns of moulding and ornamental features.
- Modern layers were removed from the central ceiling medallion and were restored by craftsmen using a rich lime mortar and natural dyes to match the existing evidence.
- Cement, whitewash and enamel paint layers were carefully removed from the entire wall and ceiling surfaces and were subsequently repaired with traditional lime mortar.
- Metal grills were installed inside the openings on the drum situated on terrace level to stop the ingress of pigeons.
- 112 merlons situated below the internal dome at gallery level were documented in detail and restored carefully.
- 34 floral medallions situated below the gallery level was found partially damaged and subsequently restored.
- Finials were found missing on the 8 minarets situated at the gallery situated above the cenotaph. Finials were prepared using a rich lime mortar and installed matching the existing site evidence.
- Original details at the cenotaph level were carefully restored on the arch mouldings, moulding bands, arch crowns using traditional lime mortar.
- The internal floor was found to be covered with a 20th-century layer of 1-inch thick cement concrete. This layer was dismantled and the site cleared of debris.
- Installation of 800 square feet of 30 mm thick granite stone slabs in approved layout matching the octagonal profile of the chamber along with an appropriate slope was carried out.
- Historically appropriate wooden doors were handmade and installed on the eastern and southern doorways.

### Impact

Completion of restoration works on the mausoleum has not only ensured long term preservation but also revived the intent of the original builder.



Removal of cement



Final lime punning



Installation of granite stone slabs

## *Reinstating the Original Plinth*

The projected plinth was covered with a thick layer of cement concrete which was removed in 2017.

### *Action Taken:*

- Multiple edge stones lining the accentuated plinth were dislocated and re-instated to their original position.
- The plinth was found to be covered with a 20th century layer of 2-inch thick cement concrete. This layer was dismantled and the site cleared of debris.
- Installation of over 4000 square feet of 30 mm thick granite stone slabs in approved layout and appropriate slope was carried out to channel rainwater away from the mausoleum.



*Removal of cement concrete from the plinth to halt further deterioration    Laying of stone slabs on a layer of lime mortar to replace the cement*

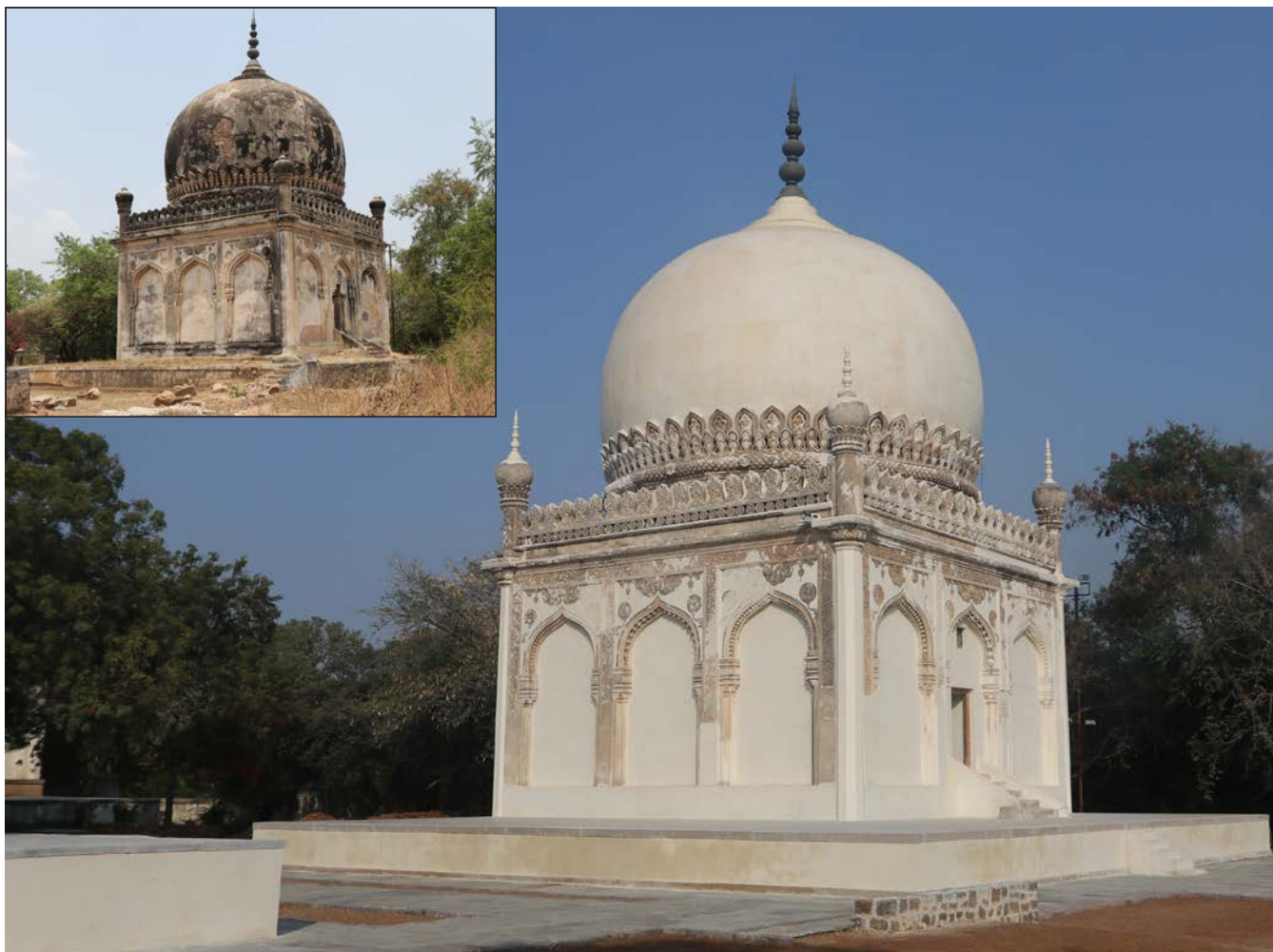

## 05 CONSERVATION OF Commander's Mausoleum



The 'Commander's' mausoleum dates from the mid 17<sup>th</sup> century. The structure is marked by profusion of ornamental stucco plaster on the parapet and base of the dome and elegant proportions on account of the high plinth and elegant proportions of the dome.

Arches on the façade are decorated with intricate geometric and ornamental mouldings, arch crowns and floral medallions, all done in lime stucco. The interiors are marked by mouldings highlighting the arches and the netting above them adorned by Shia symbols.

During recently completed conservation works, all existing original stucco work was carefully retained. In order to ensure long term preservation, 20<sup>th</sup> century cement layers from the façade and dome was carefully removed and replaced with lime mortar. During this process a number of original architectural elements were revealed and then carefully restored. The dome had deteriorated due to vegetation growth which required careful and scientific removal. Missing or partially damaged details were repaired with traditional lime mortar by master craftsmen. Missing finials as seen in the archival images have been installed on the four corner minarets.



(Left) The dome of the mausoleum of Commander was covered with 20<sup>th</sup> century cement plaster which was causing damage; (Right) After careful removal of the cement layers, lime plaster was applied on the dome.

## ***Dome:***

The dome has an approximate area of 3300 square feet. It had signs of deterioration with cracks on the surface permitting water ingress and vegetation growth. On inspection, the dome was found to be covered with a 2 inch thick layer cement mortar thereby causing the original lime plaster below to disintegrate. Multiple holes up to 2 feet deep were revealed after removal of cement plaster from the ribs. Deep roots of Peepal plants were found running along the surface of the dome and this aggravated the water seepage.

The merlons below the dome were damaged in portions and the ornate band below had majorly flaked due to perennial water seepage that had caused moisture retention inside. The drum below was also finished with cement mortar and showed visible signs of deterioration.

## ***Action Taken:***

- All the cement and loose lime plaster from the dome was carefully dismantled.
- Peepal tree roots deeply embedded in the dome masonry were carefully removed and the cracks were stitched with rubble stone and lime mortar.
- Cement patches from the dome were removed that revealed holes up to 2 feet deep that were made during the 20th century repairs and were inappropriately filled in without adequate protection against water ingress into the dome's masonry. These holes were carefully filled with stone masonry and lime mortar.
- 3300 square feet of dome surface was plastered with traditional lime mortar and finished with a 1 mm thin layer of lime punning which helps rainwater slide off the dome surface.
- Over six craftsmen were simultaneously engaged on the dome for the duration of the re-plastering to minimize the joints in successive layers of lime plaster.
- The three-tier merlons were repaired. The original details cleaned and finished while missing portions restored.
- The missing portions of the ornate band below the merlons were also similarly restored carefully matching the original in all respects. Large portions of this band were covered with 20th century lime wash which was carefully scraped.
- Cement plaster from the octagonal profile drum supporting the dome was removed and repaired with traditional lime mortar.



Before Conservation



Lime craftsman restoring the ornate stucco detail



Missing and broken details were restored in traditional lime plaster

## *Ornamental Plasterwork*

The external surface below the parapet on principal facades of the mausoleum is embellished with highly ornate lime stucco.

### *Action Taken:*

- The highly ornate stucco on the external surface of mausoleum, below the parapet, has been carefully repaired and restored by master lime craftsmen after adequate documentation.
- Over 500 man-days of work by master craftsmen was required to restore the lime stucco ornamentation on the external facade.
- During scientific removal of 20<sup>th</sup> century cement layers from stucco, old historic stucco layers with distinct floral medallions were discovered on the southern and eastern facades. These have been consolidated and retained for enhanced understanding of history.
- A number of original details were covered by the addition of modern cement plaster. These have been carefully removed in order to mitigate any unintended damage to the original details. The missing portions were restored based upon the existing site evidence.



*Missing or broken plasterwork on the facade were restored by mastercraftsmen. Original details hidden under the modern cement plaster were restored based on existing evidence.*

## Conservation of Internal Surfaces

The internal surface below the dome had signs of water seepage and with visible signs of deterioration augmented by 20th century repairs carried out using cement. Modern repairs carried out in cement led to further damaging the underlying lime plaster with increased moisture retention.

### Action Taken:

- The later added plaster layer from the internal surface of the dome was removed and a thin layer of lime plaster was applied on the surface and finished with lime punning matching the original finish.
- The central medallion of the ceiling has been duly restored, repaired and finished with lime punning. On removal of the cement from the medallion, the original pattern of ornamentation was found. The pattern has been carefully retained where revealed, thereby allowing the truthful interpretation of 19<sup>th</sup> century layer.
- The internal surface below the dome has been cleaned of the 20<sup>th</sup> century lime wash and paint exposing the lime punning surface beneath – which was found to be in good condition except in some small portions. Necessary repairs have been carried out at damaged portions and finished. Most of the original surface found to be in good condition has been retained.
- Necessary repairs to the arch gallery at the first-floor level were carried out in traditional lime mortar.
- The minarets that were damaged were repaired and the missing portions were restored. Most of the finials of the minarets were found to be damaged and were restored in lime mortar. Ornaate capital mouldings and damaged and missing portions of the ornamental stucco pattern on the arch spandrels and squinches were carefully and repaired using traditional lime mortar by master craftsmen on the lower arches of the internal surface.
- Cement concrete from the floor of the internal chamber was dismantled and the site cleared of debris. Internal flooring was laid with 30 mm thick granite slabs over an area of 800 square feet in approved layout and gradient to withstand the visitor footfall.

(Below) Restored ceiling of Commander's Mausoleum; (Bottom Left) Careful restoration of the central medallion on the internal ceiling based on evidence found (Bottom Right) View of the internal surfaces after conservation



## *Conservation of Plinth*

As with most structures in the Qutb Shahi Heritage Park, the plinth was provided only with a layer of cement concrete – allowing water ingress into the foundation and growth of vegetation and thus catalyzing deterioration. This had led to severe bulging of western and northern plinth walls made in stone masonry. Granite stone edging lining the plinth was found missing.

### *Action Taken:*

- 10 cm thick layer including the top cement concrete was removed from the plinth surface and replaced with a traditional lime concrete base.
- 30 mm thick granite stone slabs were laid atop the lime concrete in the lime mortar to provide a water-tight permanent surface, and to withstand the visitor footfall.
- Hand chiseled granite edging stone was used to line the edge of the plinth at two tiers on all the four sides to match the historical evidence revealed after clearance of earth near the north-west corner.
- Over 50 meters of plinth wall made in stone masonry was bulging as a result of water ingress. The bulged portions were carefully dismantled and reconstructed appropriately using over 1700 cubic feet of stone rubble masonry and lime.
- Steps made in hand-chiseled granite were installed on the southern facade to facilitate visitor access.



*The plinth wall at Commander's mausoleum was bulging due to water ingress, was hence dismantled and followed by reconstruction with stone and lime mortar and installation of hand-chiseled stone coping*



## Terrace & Parapet

The terrace was covered with a layer of 20<sup>th</sup> century cement concrete that aggravated the water seepage inside the mausoleum. The battlements and minarets on the parapet were severely damaged and finials on all minarets were missing.

### Action Taken:

- The damaged and missing battlements on the parapet wall have been carefully restored, repaired and finished with lime punning.
- All four corner minarets were found in a state of disrepair. The minars were carefully repaired based on physical evidence after necessary documentation. Missing finials were reconstructed in situ as per the 1860's archival image by master lime craftsmen.
- Cement concrete was removed from the terrace and replaced with traditional lime concrete laid to adequate slope towards the rainwater spouts. 12 cubic meters of traditional lime concrete was laid in appropriate gradient and cured for 7 days by craftsman.
- 20<sup>th</sup> century metal gutters from the roof were replaced with stone rainwater spouts at the terrace to drain water away from the structure.

### Impact:

Conservation effort allowed an opportunity to restore the dome as per the intention of the original builders and reinstate the original appearance, arrested the deterioration to prolong the life of the structures as a result of effective water drainage.

Conservation of ornamental stucco both on the internal and external facades as per the intention of the original builders and in turn has restored the authenticity of material, form and design of the mausoleum.

Installation of granite slabs on external plinth will help withstand the future visitor footfall and mitigate future ingress of rainwater inside the foundation of the structure. Reinstatement of the hand-chiseled granite edging will reinstate the historic formal appearance of the accentuated plinth.

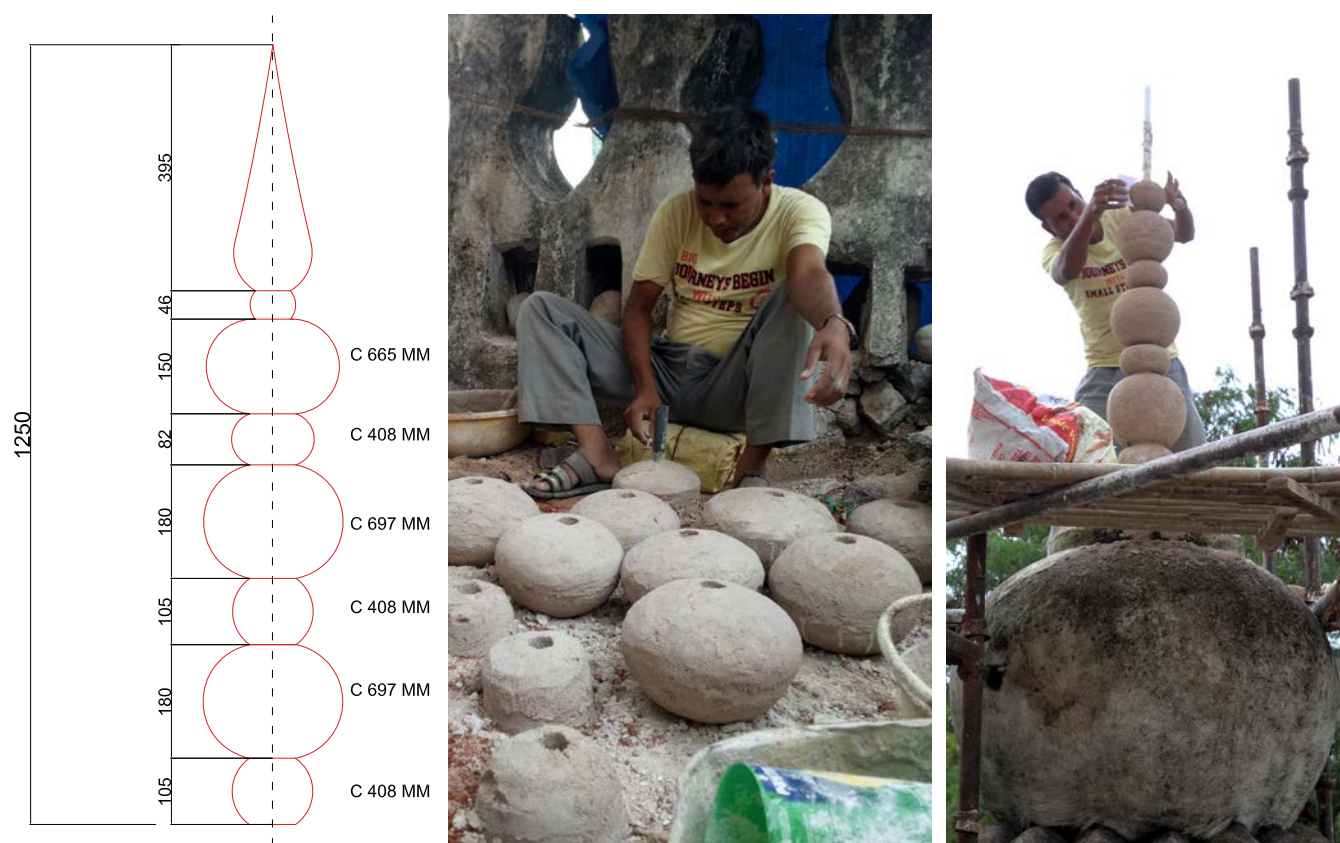

Missing finials on corner minarets were cast in lime mortar and installed in plumb matching the historic evidence.



Before Conservation



(Right) Parapet of the Hakim's mausoleum during conservation











# 06 CONSERVATION OF Hakims' Mausoleums

Hakim Nizamuddin Gilani and Hakim Abdul Jabbar Gilani were the Hakims (physicians) of Sultan Abdullah Qutb Shah. The almost identical and profusely ornamented structures have a square outer plan and an inner octagonal chamber supporting the ribbed domes. The intricate stucco works on these structures are a combination of geometric, floral and animal representations. Major conservation works were undertaken on these mausoleums with the support of the Consulate General of the Federal Republic of Germany, Chennai through 2018. To ensure long term preservation, it was required to remove 20th-century cement layers and restore lime mortar – both for plain plaster and missing stucco work. Rainwater spouts have been added – where found missing – to ensure rainwater does not cause any further deterioration. Conservation works have been carried out by master craftsmen using traditional tools, materials and building crafts as would have been used by the original builders almost 400 years ago.

**LEGEND:**



**DEFECTS IN BUILDING / PLASTERED SURFACES**

-  CRACKS IN THE PLASTER
-  DECAYED PLASTER
-  FLAKING OF FINISHING LAYER
-  INTERVENTION
-  MISSING MEMBERS
-  NEW PLASTER
-  EXPOSED MASONRY
-  CEMENT PLASTER







**DECORATIVE PLASTERWORK**

-  DECAYED PROFILES
-  MISSING PATTERNS

**WATER PROBLEMS**

-  WATER SEEPAGE
-  WATER RISE

**SURFACE DEPOSITS**

-  ALGAE
-  BLACK CRUST
-  GRAFFITI
-  LIME WASH
-  DEPOSITS
-  VEGETATION



(Above) Restoration of the ribs on the dome of Hakims mausoleum in lime mortar

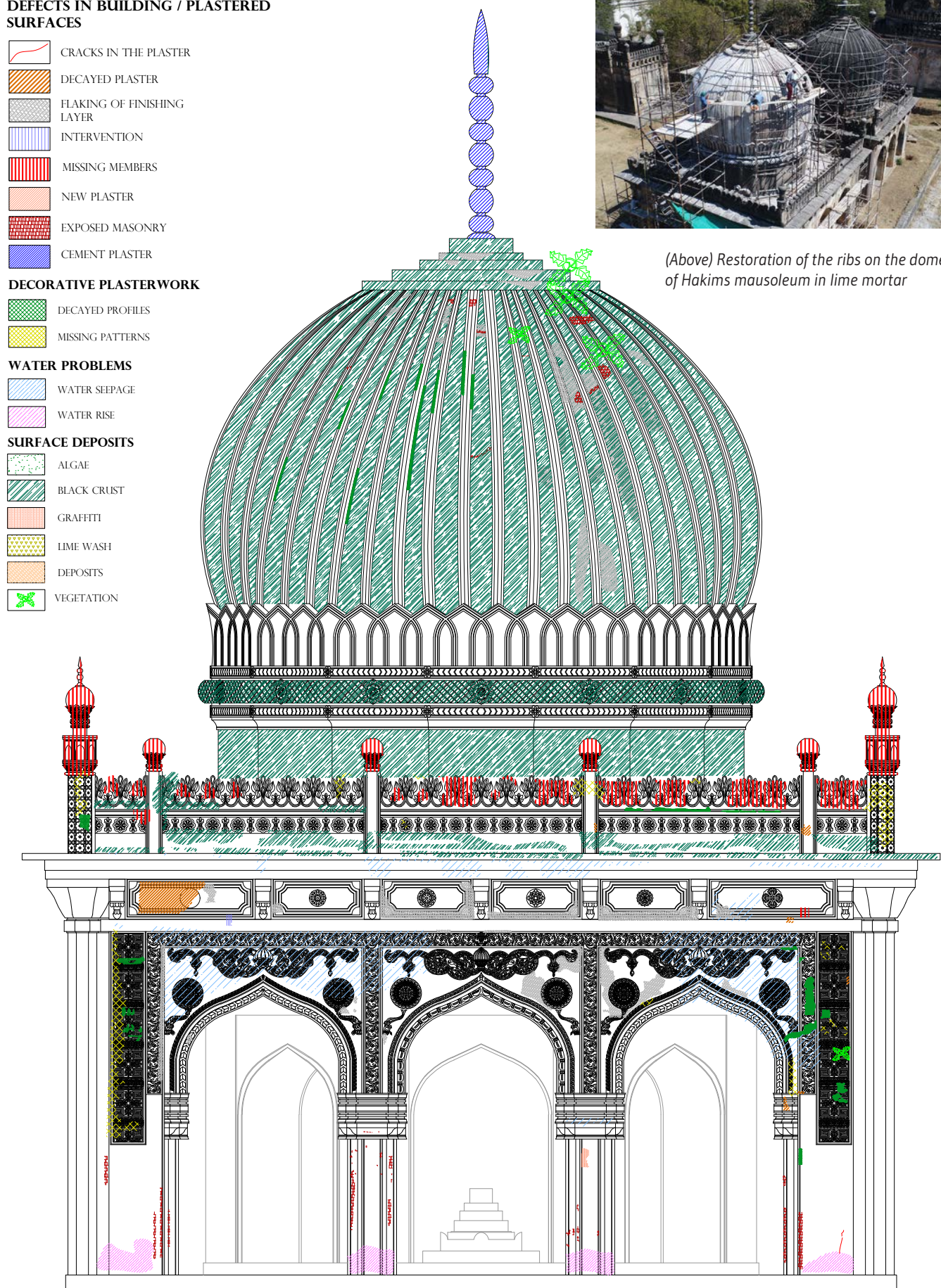

Detailed condition assessment of of the mausoleum situated to the west

## *Domes*

The ribbed domes of the twin mausoleums measuring 5 meters in diameter and over 7.5 meters in height have an individual approximate area of 2200 square feet. They had signs of deterioration with cracks on the surface permitting water ingress and vegetation growth. On inspection, the domes were found to be covered with an inch thick layer of cement mortar thereby causing the original lime plaster below to disintegrate. Multiple holes, up to two feet deep, were revealed after removal of cement plaster from the ribs.

The merlons below the dome were damaged in portions and the ornate band below had vegetation growth loosening the mortar and causing moisture retention inside. The drums below were also finished with cement mortar and showed visible signs of deterioration.

### *Action Taken:*

- All the cement and loose lime plaster from the domes was carefully dismantled.
- Removal of cement revealed holes, that were up to 2 feet deep, in the dome surface and which were thought to have been made during 20th century repairs to support the scaffolding and later superficially filled without adequate protection against water ingress into the dome's masonry. All these holes were carefully repaired with stone masonry in lime mortar.
- 2200 square feet of surface was plastered with traditional lime mortar, and finished with a 1 mm thin layer of lime punning. Over 10 craftsmen were simultaneously engaged on each dome for the duration of the re-plastering to minimize the joints in successive layers of lime plaster.
- All 96 ribs on both the domes were repaired with traditional lime mortar, and their curvature was matched to the existing design.
- The merlons were repaired with the original details cleaned and finished with missing portions restored.
- The missing portions of the ornate band below the merlons were also similarly restored carefully matching the original in all respects.
- The highly ornate diamond shaped band, merlons at the neck of the dome and the band below were scraped of the 20th century cement layer and repaired in damaged portions with lime mortar.
- Cement plaster from the octagonal profile drum supporting the dome was removed and repaired with traditional lime mortar.





## *Finial*

20<sup>th</sup> century cement finial made with steel reinforcement was installed on top of western dome in the 1970s. This was removed and a copper finial matching the historic copper finial on top of the eastern dome was fabricated by a coppersmith over a span of 3 months and subsequently installed.

### *Action Taken:*

- Upon close inspection of archival images, the finial on the mausoleum to the west was found to be added since 1976, and was constructed in cement concrete. Cue was taken from the other mausoleum which had an old copper finial. A thorough documentation of the finial of the existing copper tomb was carried out before a matching copper finial was fabricated.
- A local coppersmith was identified for the work. In around 80 days, the coppersmith completed the fabrication of the similar finial, composed of 11 hollow copper vessels of matching size and shape were built in 99.5% pure copper and 1.6 mm thick copper sheet as the existing copper finial on the dome situated to the east. Scientific investigations to check the purity of the copper sheet preceded the fabrication of copper vessels.
- 11 individual hollow copper vessels of matching size and design were fabricated by the traditional coppersmith using hand tools. A true scale mock-up with a steel skeleton covered with hollow copper vessels was erected to ascertain whether the new finial could withstand the wind load,
- The finished copper finial was carefully installed on the top of the dome after placing adequate skeleton inside to withstand strong winds and rain.

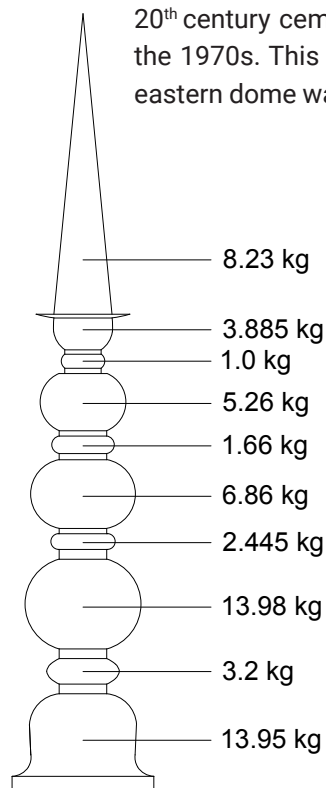

Total weight= 60.44 kg

(Left) Detailed documentation of the existing finial of the Hakim's mausoleum to the east before installation of the missing topmost cone was carried out



*Installation of finial on the western dome of the twin mausoleums of Hakims'. (Top Left) Cement finial on the mausoleum to the west ; (Top Right) Local coppersmith fabricating components of copper finial; (Below) Installation of the finial on the dome*

## *Stucco Ornamentation*

The external surface below the stone eaves on principal facades of the twin mausoleums is embellished with highly ornate lime stucco.

### *Action Taken:*

- The highly ornate stucco on the external surface of the twin mausoleums, below the stone eaves band, have been carefully repaired and restored by master lime craftsmen after adequate documentation.
- Intricate geometric details below the stone eaves covering an area of over 100 square meters have been carefully repaired and restored in the missing and damaged portions by highly skilled lime craftsmen engaged over 150 days.
- Over 900 man-days of work by master craftsmen was required to restore the lime stucco ornamentation on the external facade.
- Repairs in ornamental stucco done using cement in the 20<sup>th</sup> century was carefully scraped and intricate patterns were restored using traditional lime mortar by the master craftsman.
- A number of original details were obfuscated by the addition of modern cement plaster. This was carefully removed in order to mitigate any unintended damage to the original details. The missing portions were restored based upon the existing site evidence.
- The facade on all the four sides of twin mausoleums was restored with highly ornate stucco plaster in form of floral-geometric and animate objects, medallions in the spandrels of the arches, arch crowns and moulding bands based on existing evidence, impressions that could be discerned by referring to archival images.

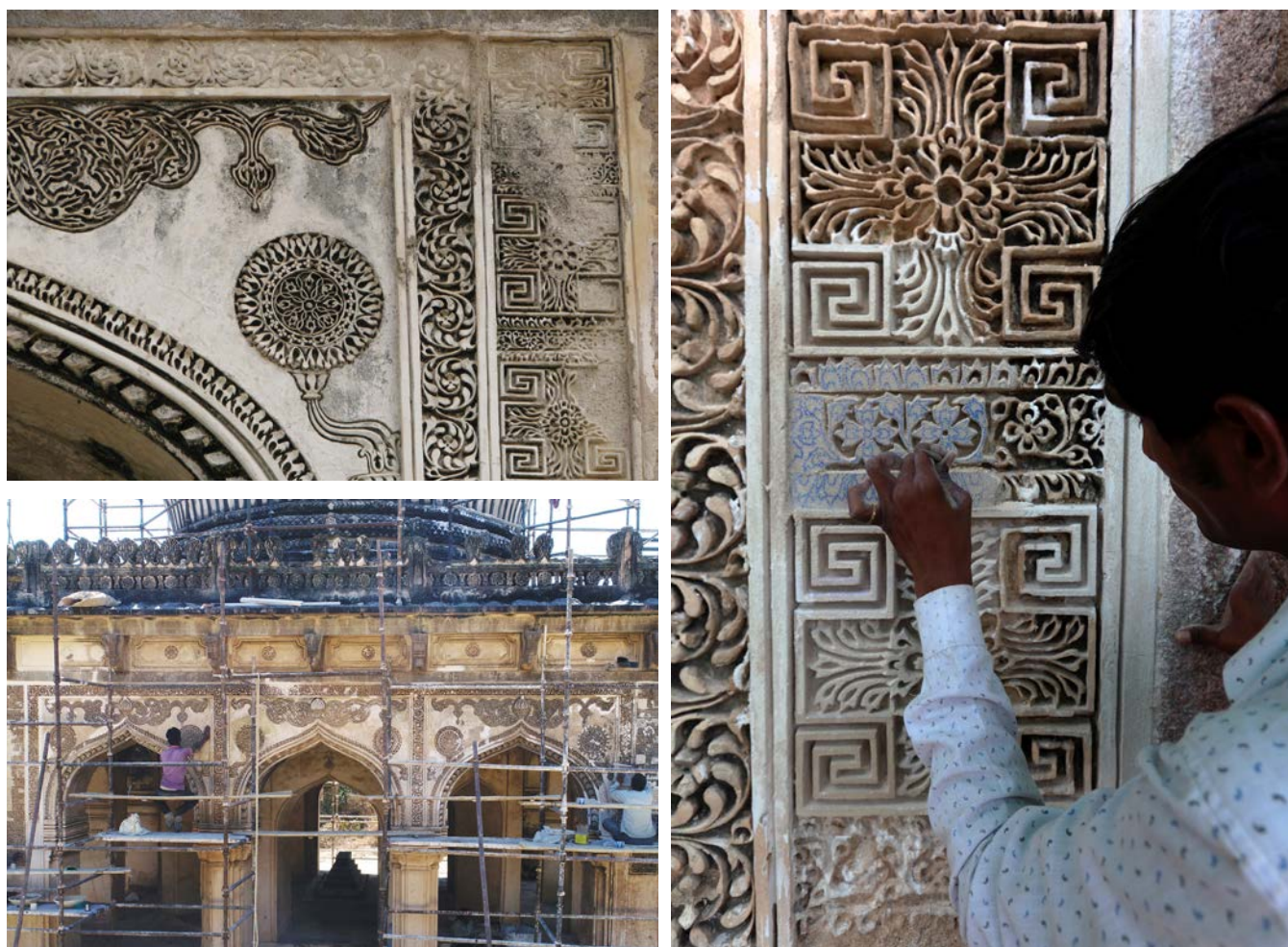

*Missing and damaged ornate stucco patterns on the external facade of the twin mausoleums of Hakims' were carefully restored by craftsmen*



Before Conservation



After Conservation



Reconstruction of missing minarets



Laying of lime concrete on the terrace

## *Parapet & Terrace*

The battlements and minarets on the parapet above the eaves were severely damaged and missing in portions. The terrace was covered with a layer of 20<sup>th</sup> century cement concrete and aggravated the water seepage inside the mausoleums.

### *Action Taken:*

- The damaged and missing battlements on the parapet wall have been carefully restored, repaired and finished with lime punning on both the mausoleums.
- Portions of the missing small minarets on the parapet wall were found on the terrace of the mausoleums. Based on the existing evidence, these portions were reinstated in 6 minarets after the restoration of the missing details. 22 small minarets were reconstructed as per the existing evidence with the ornamentation and reinstated on the parapet wall.
- Only 3 of the 8 corner minarets were found intact in their original positions on the parapet of the twin mausoleums. The minarets were carefully repaired based on physical evidence after the necessary documentation. 5 minarets were reconstructed in situ as per the lone existing minaret by 5 master lime craftsmen in over 70 days.
- Cement concrete was removed from the terrace and replaced with traditional lime concrete laid in an adequate slope towards the rainwater spouts on the mausoleum to the west. The metal gutters from the roof were replaced with stone rainwater spouts at the terrace of the mausoleum to the west.
- Four stone water spouts were installed on the terrace of mausoleums to drain rainwater away from the structures.



## *Internal Surfaces*

The internal surface below the dome had signs of water seepage and a thin layer of finish was flaking at several portions. Modern repairs had been carried out in cement which led to further damage to the underlying lime plaster.

### *Action Taken:*

- Conservation works on the internal surfaces commenced after two months of removing the cement plaster – which is the time required for the masonry to dry out.
- Upon removal of cement layer, ribs projecting from the ornamental ceiling medallion were discovered. They were repaired with traditional lime mortar.
- The ceiling of the internal domes had medallions which were partially damaged due to water ingress. These medallions were repaired and restored with lime mortar and finished with lime putty as per the original.
- After cleaning the wall and ceiling surfaces of mausoleum interiors manually using brushes and water, any loose plaster and cement were dismantled.
- The battlements were repaired and restored using traditional lime mortar.
- Intricate arch crowns, floral medallions, and arch moldings were restored by master craftsmen with traditional lime mortar.



Before Conservation



After Conservation



Before Conservation



After Conservation



Plinth: Before Conservation



Plinth: After Conservation

## Plinth

As with most structures in the Qutb Shahi Heritage Park, the plinth was provided only with a layer of cement concrete – allowing water ingress into the foundation and growth of vegetation and thus catalyzing deterioration.

### Action Taken:

- 100 mm thick layer including the top cement concrete was removed from the plinth surface and replaced with a traditional lime concrete base.
- 30 mm thick granite stone slabs were laid atop the lime concrete in lime mortar to provide a water-tight permanent surface. This would also not be susceptible to wear and tear with high numbers of visitors and would channel the rainwater away from the structures.
- The internal cement flooring was replaced with granite slabs in an approved layout and appropriate gradient.
- 100 mm thick rough textured granite stone slabs were laid to an appropriate slope and approved pattern on the edge of the plinth.
- Steps made in hand-chiseled granite were installed on the southern facade to facilitate visitor access.
- Over 5000 square feet of granite stone slabs were cut to size and laid on the external plinth and inside the twin mausoleums.
- Over 50 meters of plinth wall made in stone masonry was bulging as a result of water ingress. The bulged portions were carefully dismantled and reconstructed appropriately.



Installation of 30 mm thick granite stone slabs



Installation of hand-chiseled granite steps

### Impact

Reinstatement of copper finial, ornamental stucco, parapet and accentuated plinth as part of the conservation effort allowed an opportunity to restore the architectural elements as per the intention of the original builders and in turn has restored the authenticity of material, form, and design of the mausoleum.



*(Above) Before conservation view of Muhammad Qutb Shah's Mausoleum; (Right) An artist's rendering of the Tomb of Muhammad Qutb Shah with tilework on the dome and facade. Watercolour illustration by: Himanish Das*

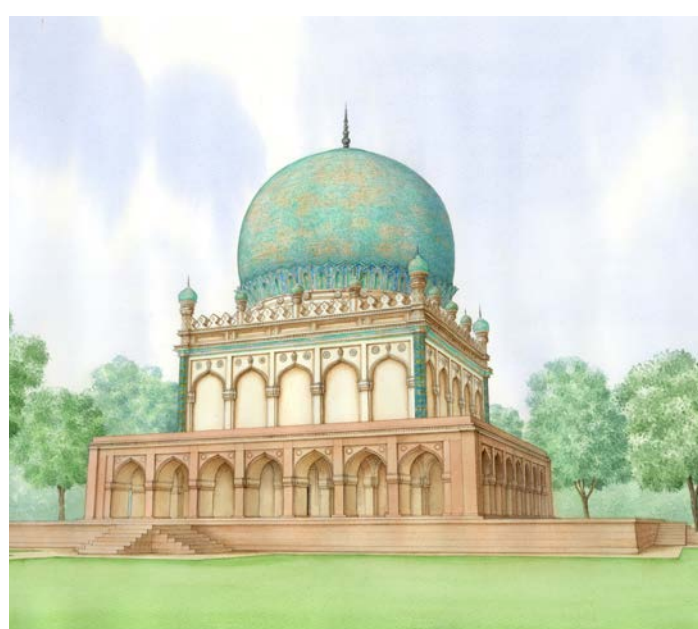

## 07 CONSERVATION OF Muhammad Qutb Shah's Mausoleum

In 2017, erection of scaffolding around the dome of the mausoleum was carried out to investigate the historic glazed tiles obfuscated by a 3 inch thick layer of 20th century cement plaster. For the preliminary investigation, cement layer on the south-western quadrant of the dome was meticulously chipped off using small-sized hand tools. Archival images from 1870s suggest that the external facade of the tomb consisted of extensive tile work. During the 20th century repairs, the facade was covered with cement thereby damaging the surface below.

## *Preparatory Works*

The archival research conducted in the various national and international museums, libraries provided not only a thorough timeline of the evolution of the site but also a sequence of conservation works carried out. It is pertinent to know the 20th century interventions carried out on the structures.

Prior to commencement of conservation works, required time will be devoted to completing the archival research, detailed architectural documentation and material investigations.

Material investigations have been carried out through use of a Scanning Electronic Microscope, and Energy Dispersive X-Ray Spectroscopy aid in determining the firing temperature of the kilns. Findings of material testing such as composition of tile, its glaze and firing temperatures will result in better understanding and replication of the historic tiles in a precise yet appropriate manner.

In addition, precise architectural drawings will be made using the high definition three dimensional laser scanners which will document with a resolution of 2 mm. A detailed condition assessment comprehensively mapping the extent of damage to the structure and surface details will help in coming up with appropriate solutions.

Photographic survey of the buildings with focus on intricate stucco details will simultaneously be carried out. One of the key aspects of documentation works is an exhaustive, high-resolution photography of all stages of conservation works. These photographs are used to not only assist the conservation decisions, but also produce a photographic and true record of the building, and maintain it for posterity. This will be available to the donor.

Based upon in-depth analysis of scientific investigations, architectural documentation, archival research and detailed photographic surveys, conservation works would be commenced.



*Tile Documentation*

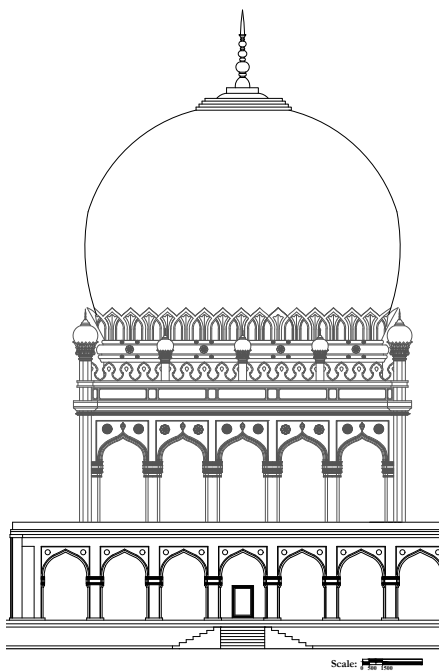

*Documentation*

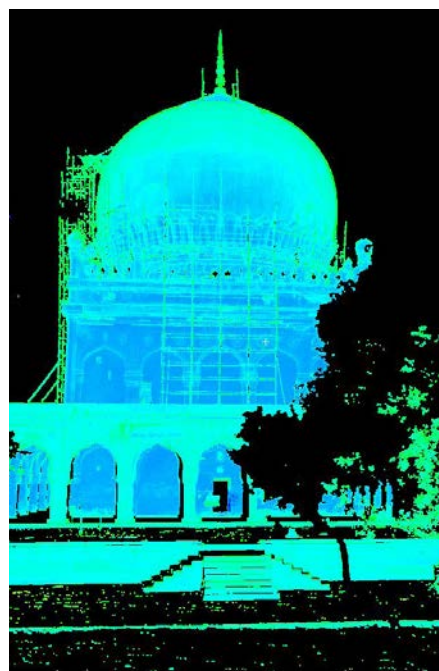

*3D Laser Scanning*

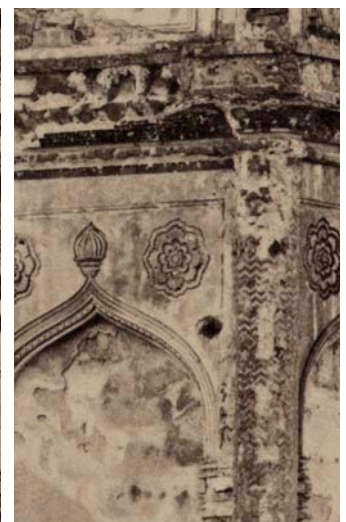
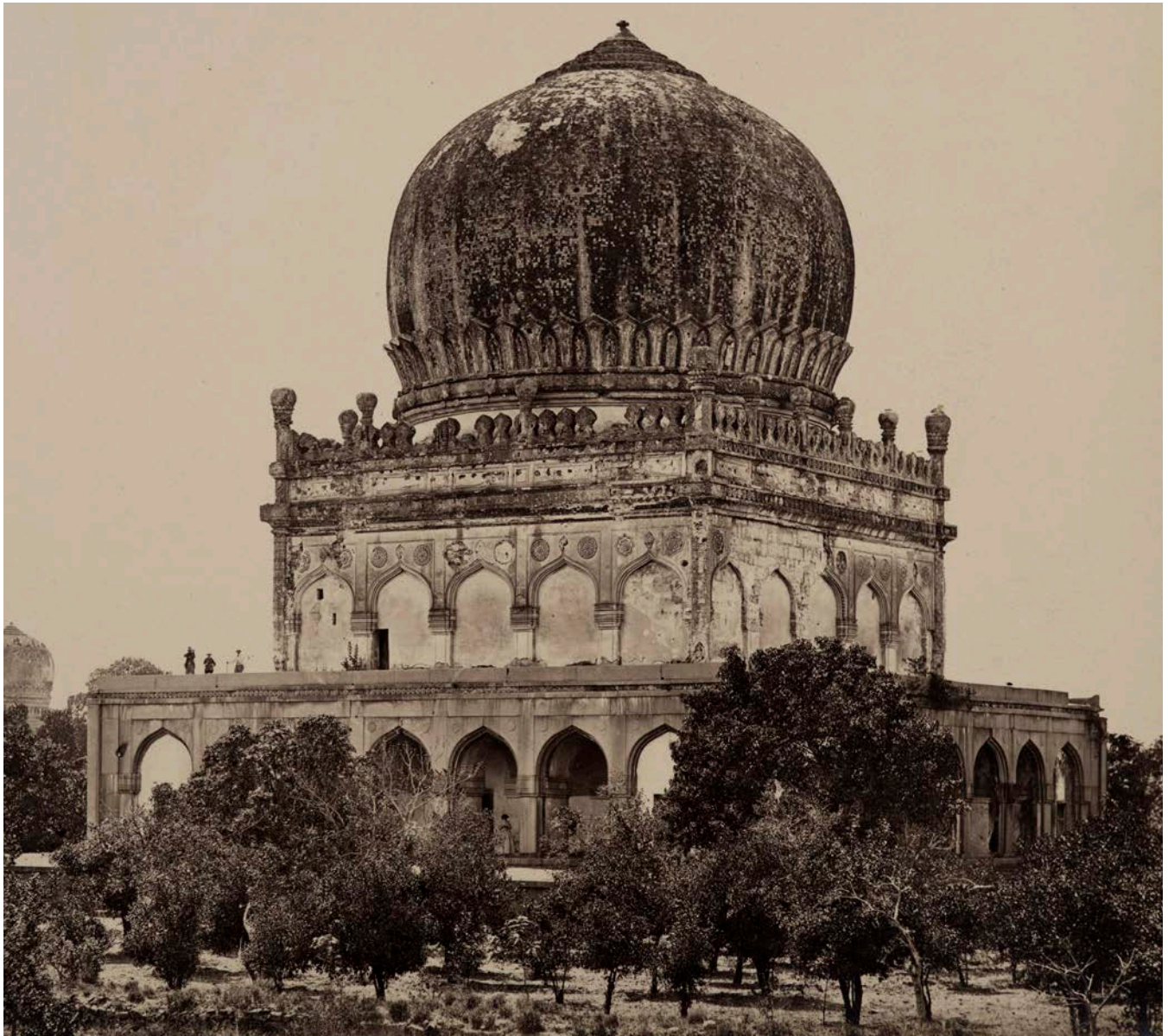

*Archival image from the 1860s showing evidence of original tile patterns on the dome, merlons at the base of the dome, horizontal bands on the facade and the corner minarets. (Image source: Alkazi Foundation)*

## *Dome*

Investigations of dome surface, documentation of revealed tiles and consolidation of tile surface on this building were commenced in April 2017 and carried on for three months. Consolidation of surface around tiles was done to prevent further ingress of rainwater into the masonry and in turn aggravating the damage to the remaining glazed tiles and tile bases on the dome surface.

After careful scraping, later added cement plaster was removed, revealed tiles were documented, and assessment of damage to tiles and base surface was carried out. Approximately eight tonnes of 20th century cement plaster was removed. This not only reduced the excess load on dome but also revealed the original tile patterns.

Over 60 deep holes were discovered on the dome surface, with depth ranging till ten feet have been filled by using lime mortar and rubble stone. The depressions on the surface of dome around the rings supporting the finial were consolidated using lime mortar and matched with the base level of revealed tiles. This was done to mitigate water logging in these depressions from seeping into the masonry below.

All of these had the same colour though they were found in different locations. In addition, 15% of the tiles survived though in most of these, the glaze has been lost. Approximately 25 % of missing tiles have their imprints in lime plaster visible across the dome surface. Detailed condition assessment of the state of decay of the existing tiles was carried out at site and marked on drawings.

The area of the dome was carried out to facilitate detailed documentation of existing tiles and about 20 tiles with their glazing intact were discovered. All of these had the same colour though they were found in different locations. It revealed that approximately 150,000 green coloured tiles will need to be manufactured to restore the dome surface.



Similarly, remnants of original tile patterns were uncovered at various parts of the facade. The merlons at the base of the dome, horizontal bands at the drum of the dome, minaret shafts and facade bands were found to have tile details in various colours. Another 50,000 tiles in different colours will be required to restore the surface of lower facades. Later added 20th century brick infill was removed to reveal the original base surface of external dome.

### *Next Steps:*

- Dismantling the 20th century cement concrete from quarter of dome to assess the condition of tiles. Scaffolding to be erected to investigate the condition of tiles both on the dome as well as the façade based on existing archival evidence.
- Deep holes in the dome masonry to be repaired with stone and lime mortar.
- Investigations shall also be carried out at the base of the dome and the 20<sup>th</sup> century cement plaster layer shall be dismantled.
- Vegetation shall be removed from the dome as well as the facades of the monument.



*Evidence of original glazed tiles*

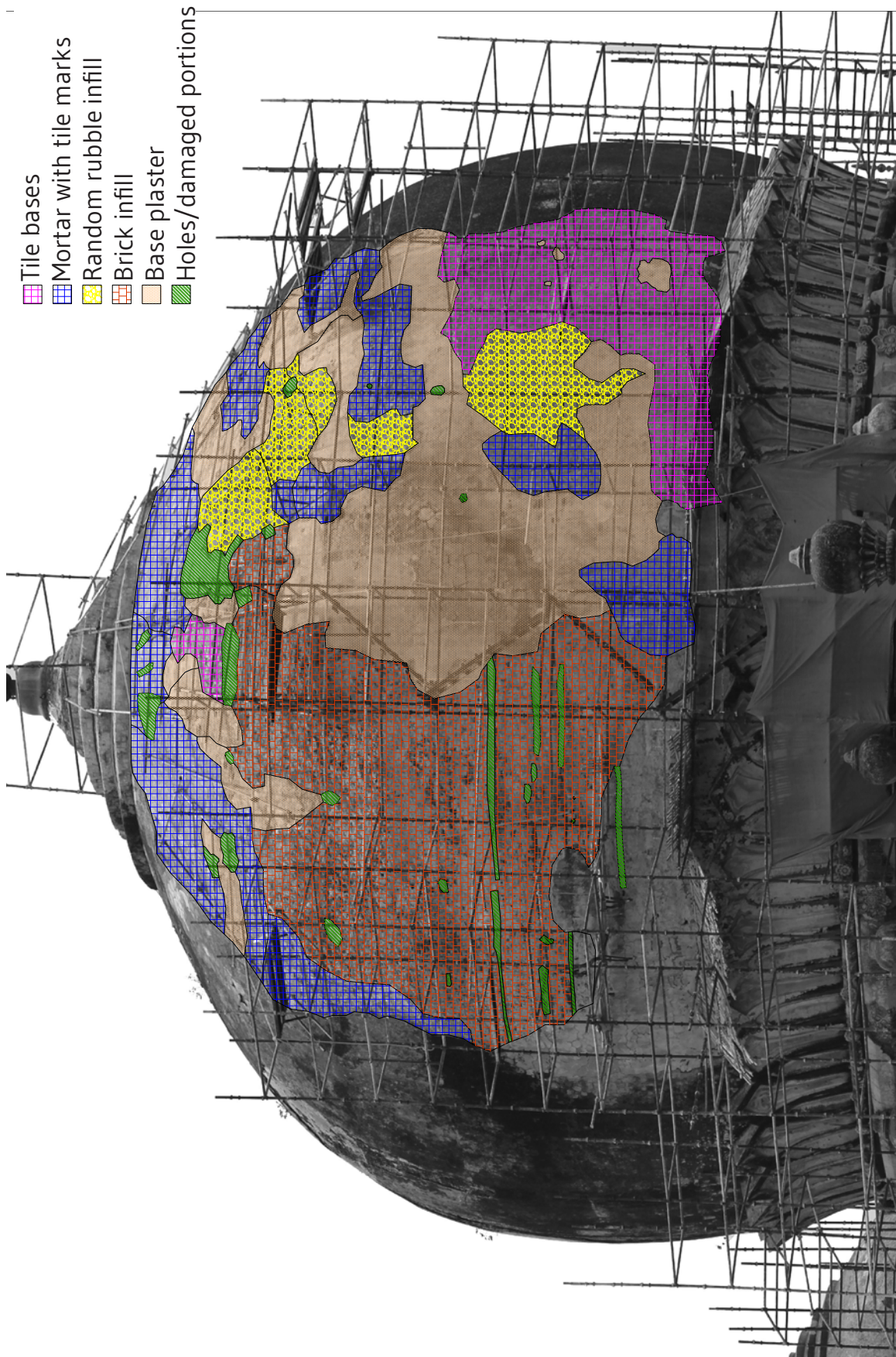



*During Conservation**Before Conservation*

# 08

CONSERVATION OF

## Hayat Bakshi Begum's Mausoleum

Hayat Bakshi Begum, better known as Ma Saheba, took a prominent part during the reign of three Qutb Shahi rulers. She was the daughter of Muhammad Quli Qutb Shah, wife of Muhammad Qutb Shah, and mother of Abdullah Qutb Shah.

Her mausoleum is a replica of the mausoleum built for her husband, both in terms of scale and size. In late 2018, removal of later added cement plaster layers was commenced on the dome surface. The dome was covered with a 2 inch thick layer of cement plaster and showed signs of deterioration permitting ingress of water and vegetation growth.

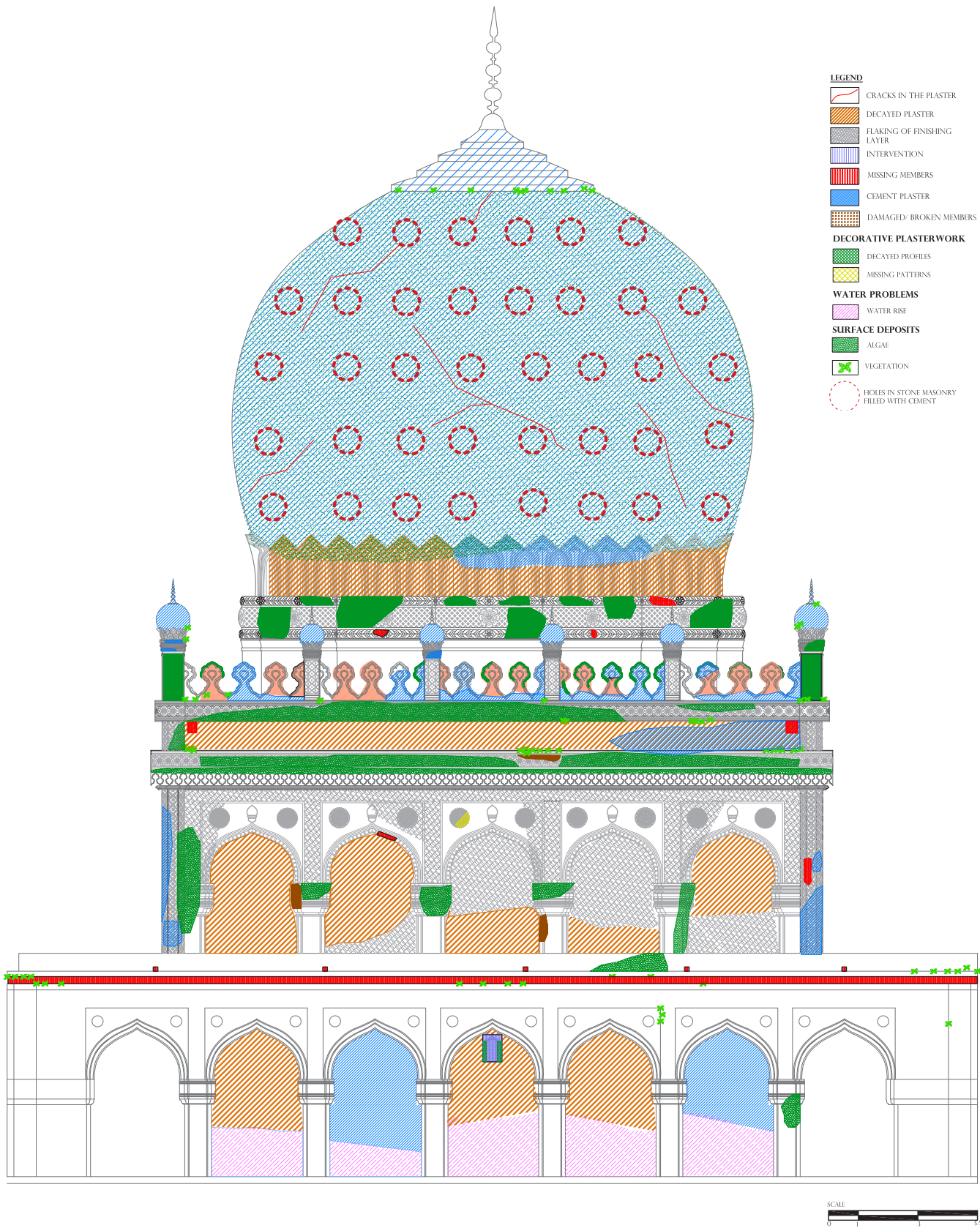

Conidition assesment of northern elevation of Hayat Bakshi Begum's mausoleum

***Action Taken:***

- 20<sup>th</sup> century cement layer from the external dome was carefully removed to reveal over two hundred holes made for previously installing wooden scaffolding. Some of these holes were up to ten feet deep and covered up with cement mortar. These holes were filled up with rubble stone and lime mortar to prevent the ingress of rainwater, thus preventing.
- Over ten thousand square feet of external dome surface was re-plastered with traditional lime mortar and upon setting, covered with a thin and smooth layer of 1-millimeter thick punning, to mitigate future ingress of rainwater and facilitate skidding away of water from the dome surface.

***Next Steps:***

- Necessary repairs in traditional lime plaster to be carried out at to prevent future ingress of water on 128 merlons situated below the dome.
- Repairs and restoration of parapet battlements and minarets to be carried out by master craftsmen to restore the original appearance of the monument.
- Plastering to be carried out inside the double dome after removal of the dilapidated lime plaster layer.
- A layer of lime concrete will be laid over the highly uneven sloped flooring of the double dome to provide a leveled surface.

**Impact:**

Repairs carried out on the massive dome by master craftsmen to restore the original appearance of the monument have reinstated the original appearance shed the ubiquitous visual character bestowed by 20<sup>th</sup> century cement plaster repairs. Restoration of the dome has, in fact, honored the intentions of the original builders.



Removal of 20th century cement from the dome



Replastering of dome with lime mortar



Repairs on the merlon band below the dome

# Baolis at Qutb Shahi Heritage Complex

The 106 acre Heritage Park boasts of seven baolis that were created here by the Qutb Shahi rulers to irrigate the orchards. The ongoing conservation effort aims to repair and revive each of these baolis as well as create ecological zones on the northern and southern edge where over 10000 native trees are to be planted.



Baoli North of Sultan Quli Qutb Shah's Tomb



Baoli North Of Hamam

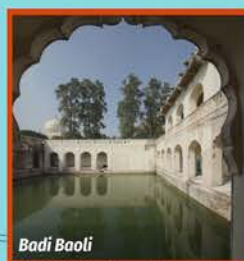

Badi Baoli



Baoli in Deccan Park



Baoli to the West of Janshed Quli Qutb Shah's Tomb



Baoli to the South of Idgah



Baoli to the East of Fatima Sultan's Tomb

## Badi Baoli

Conservation of the Badi Baoli, after its collapse in 2013, required over 4000 man-days of work was required to clear the Baoli of collapsed masonry, under extremely dangerous conditions but the reconstruction of 600 cu.m. of stone masonry has led to an annual collection of 3 million litres of water – now used for irrigation and conservation works.



*Reconstruction of masonry arches above western wall at Badi Baoli*

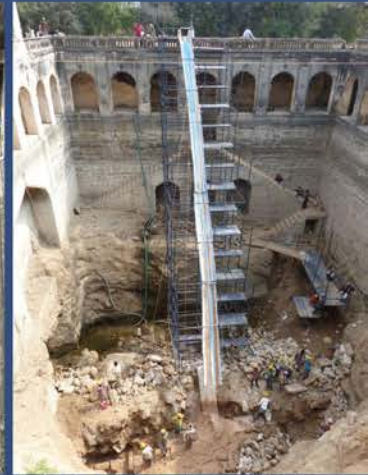

*Construction of retaining wall using traditional lime mortar*



*Existing stones from the collapsed western wall reused for repair of the wall.*



HERITAGE TELANGANA  
GOVT. OF TELANGANA



AGA KHAN TRUST FOR CULTURE



# 09 CONSERVATION AND PREVENTIVE MAINTAINENCE

## Baoli to the south-east of Ibrahim's mausoleum

The "T" shape baoli is located to the south of the Idgah and is one of the grandest baolis within the Qutb Shahi Heritage Park.

The 16<sup>th</sup> century baoli is constructed in dressed granite stone masonry using local granite with stepped retaining walls in ashlar masonry. The lowest portion of the retaining wall rests on the natural rock. A series of steps from the southern side of the baoli lead to a covered landing. From the west side of this landing is another series of steps that lead you to the lowest landing from where along the south-eastern edge a final flight of steps lead you to the base of the baoli.

Due to lack of upkeep and periodic maintenance, baoli was in a dilapidated condition and number of stones were bulging from the wall line.



*All the displaced dressed stones were realigned into place using the existing stones as reference* *Thick tree roots were removed carefully to mitigate any further displacement and movement to the stones.*

### ***Action Taken:***

- Dressed stone façade was cleaned of lime and algae deposition caused as a result of perennial leeching of rainwater from neighbouring areas.
- Lower steps leading to the baoli were cleared of debris and heavy vegetation.
- De-silting of baoli was carried out for 30 days employing over 10 labour to remove the sludge.
- Blocks of hand chiseled granite stone on the western, southern and northern sides were found bulging. These stones were reinstated in their original location along the wall line.
- Thick tree roots were found in the northern and western edge of the Baoli and were removed carefully to mitigate any further displacement and movement to the stones.
- Lime concrete was laid in portions on top of the double-height vault spanning the landing of lower steps to prevent the ingress of water.

### ***Next Step:***

It would be critical to restore the highly ornamental stucco medallion on the northern internal wall of the baoli due to the dilapidated condition of the stucco. Missing hand dressed stones on the south-eastern corner need to be reinstated along with the external collapsed eastern wall. Pointing needs to be carried out on the rubble masonry wall supporting the ramp situated on the southern wall.

### **Impact:**

De-silting of baoli and removal of heavy vegetation has revealed the original appearance of the baoli as envisaged by the original builders. Removal of sludge and cleaning of lime deposition has accentuated the inflow of rainwater from neighboring areas leading to increased levels of water in 2017-18.

# 10 CONSERVATION AND PREVENTIVE MAINTAINENCE

## Baoli to the west of Jamshed's mausoleum

This Baoli built over the natural rock is rectangular in plan. The retaining walls built at three levels are constructed using local granite in rough stone masonry. In some places, random rubble stone masonry with coping stones is also used. Two flight of steps along the southern façade leads to the second level of the baoli, from which a smaller flight of steps leads to the base of the baoli. Almost all the facades of the baoli are majorly natural rock. Conservation works had to be commenced after ensuring removal of sludge during de-silting in 2017.



*Parapet masonry wall being repaired on eastern, western and southern sides*



*Channelization of rain water from adjoining areas into the Baoli*



### ***Action Taken:***

- Missing hand dressed edging stones on the eastern, western and southern ledge of the baoli were installed.
- Repairs of the stone steps leading to the baoli carried out by the stone craftsmen and a flight of steps leading to the lower parts of Baoli were reinstated.
- Water spouts linked to the trench drains constructed as per landscape master plan were installed on the southern and eastern walls of the baoli to channel the rainwater into the baoli.
- Crevice situated beneath the water spout installed on the southern wall was filled with rubble masonry and finished with lime concrete to mitigate future damage to the crumbling rocks. Four masons were employed for two weeks to complete the masonry employing rubble stone and lime mortar.
- Original rubble masonry parapet was repaired by masons using traditional lime mortar after removal of 20th-century cement plaster.
- A low height brick parapet was installed above the southern, eastern and western masonry parapet to prevent visitors from tripping inside the baoli.

### **Impact**

De-silting of baoli and reconstruction of steps, retaining walls and restoration of missing stone edging has revealed the original appearance of the baoli as envisaged by the original builders. Installation of multiple waterspouts linked to subterranean trench drains is channeling the rainwater directly into the baoli.

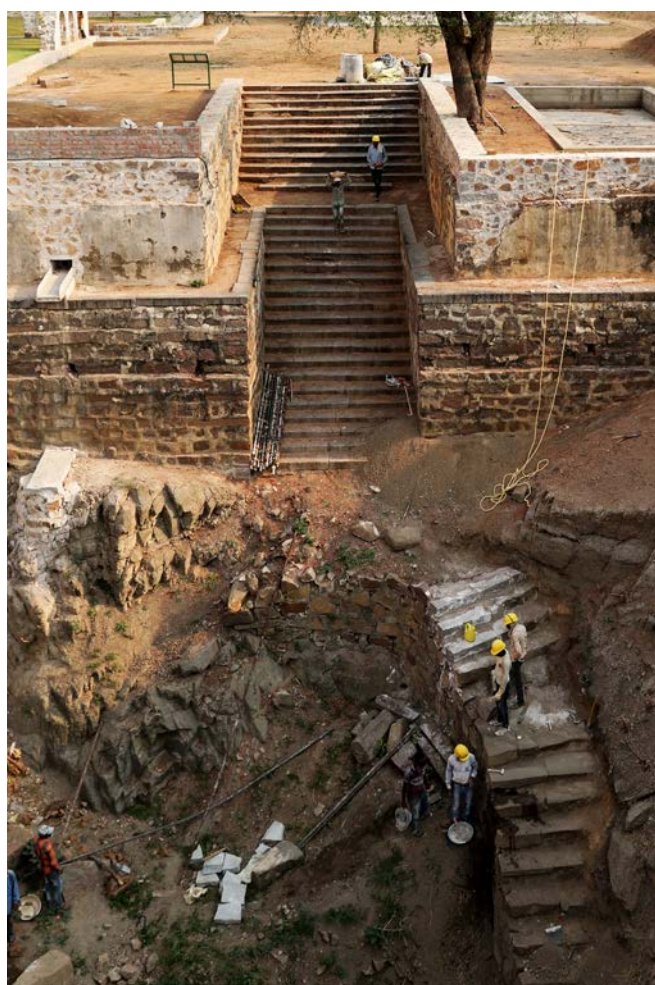

*Repairs of the steps carried out, missing steps were reinstated*



*Missing hand dressed edging stones on the western and southern ledge of the baoli were installed*



## **11** CONSERVATION AND PREVENTIVE MAINTAINENCE

### **Baoli to the north of Sultan Quli's mausoleum**

The deep well situated to the north of Sultan Quli Qutb Shah's mausoleum is the smallest stepwell situated in the tomb complex. Water drawn from the baoli was channeled into the adjoining water channels running along the entire length of the Hamam.

Before commencement of conservation works, corner walls of the arcade above the baoli had partially collapsed and the baoli was inaccessible due to heavy foliage obstructing access. Collapsed masonry of the well structure was reconstructed, and the adjacent structures were cleared and repaired.

***Action Taken:***

- De-silting was followed by removal of thick vegetation creating access to the structure.
- Repair of partially collapsed masonry on western piers coupled with the raking of 20<sup>th</sup> century cement pointing was followed by re-pointing of masonry walls using lime mortar by stonemasons.
- Repairs of ancillary portions beneath the ramp was carried out and re-plastering of connected water tanks has been completed.

**Impact**

Completion of conservation works has stalled the deterioration process that was adversely affecting the structure. Grading of adjoining terrain has led to channeling of rainwater along the western enclosure wall into the shallow baoli.



*(Left) Aqueduct to the east of baoli; (Top right) Missing hand dressed edging stones on the western and southern ledge of the baoli were installed; (Bottom right) Low height brick parapet installed to prevent visitors from tripping inside the baoli*



# 12 CONSERVATION OF Hayat Bakshi's Mosque

Conservation works have been going on intermittently on the mosque since starting of 2018. There were serious structural damages on the south-eastern corner minaret coupled with seepage on the terrace. Works need to be carried out on the north-eastern corner minaret and the terrace.

### *Action Taken:*

- Installation of scaffolding from the ground till the top of the south-east corner minar was first undertaken. Dismantling of 20th-century cement plaster and subsequent repairs with traditional lime mortar were carried out.
- During the conservation of damaged stucco, visible signs of rainwater ingress could be seen in the bulged and damaged portions. Retrofitting with hollow stainless steel bars to reinforce the cantilevered portions was carried out.
- Extensive plant root growth was observed during the removal of later added layers. Subsequent repair with lime mortar helped in the drying of the imbibed moisture as lime being a relatively porous material allows the absorbed moisture to dissipate into the air.
- Further ingress of water was stopped due to the lime mortar grouted in the cracks which earlier led to bulging of plastered surfaces on the minar. Apart from long term preservation, grouting helps fill the voids on surfaces to the rear masonry.
- Dismantling of inappropriate late-20th century stone flooring was carried out to reveal the original floor levels.



A: Dismantling of inappropriate 20<sup>th</sup> century stone flooring; B: Carving of floral medallions by lime craftsman ; C: Reinforcing damaged portion of minarets with jute fiber and lime mortar; D: Finishing of restored floral brackets supporting the arch gallery

***Next Steps:***

Restoration works on the corner minarets will be completed. This will be followed by the removal of 20<sup>th</sup>-century cement concrete which will be replaced with traditional lime concrete, that shall be carried out after the monsoons.

**Impact:**

Structural repairs and stucco restorations will help ensure long term preservation coupled with reviving the intentions of the original builders.



# 13 CONSERVATION OF Hamam: Serai

The Hamam at the Qutb Shahi Heritage Park is one of the finest surviving specimens of a Persian bath in India. A major portion of the Hamam Serai had collapsed as indicated by the archival images sourced from 1870's.

### *Action Taken:*

- Projected stone eaves were installed on the southern and northern facade of the main structure based on physical evidence. Final plaster on the southern facade below the chajja was applied using lime mortar and finished with a coat of lime punning after the restoration of the missing details. All the chajja stones were installed in position on the east, south arm of the sarai and the southern external facade based on the archival evidences.
- 0.75 meter high random rubble masonry parapet wall was built over these chajjas matching the evidence depicted in archival photographs from 1870's.
- Upon removal of cement concrete from the roof, lime concrete beneath was found damaged at many portions. The lime concrete was dismantled and a fresh coat of traditional lime concrete was laid on the roof to adequate slope and proper treatment.



*Stone eaves installed on the facade of serai*

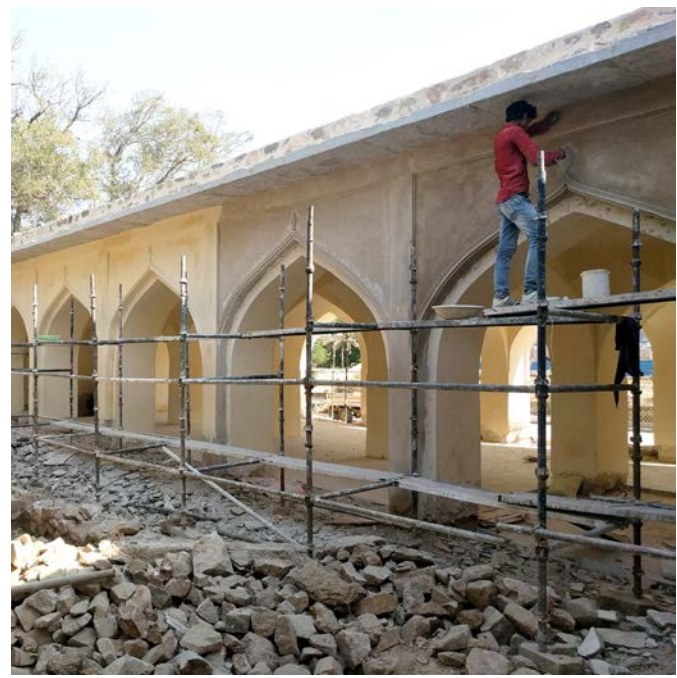

*Repairs on the facade in lime after removal of 20<sup>th</sup> century cement layers*

## PROPOSAL

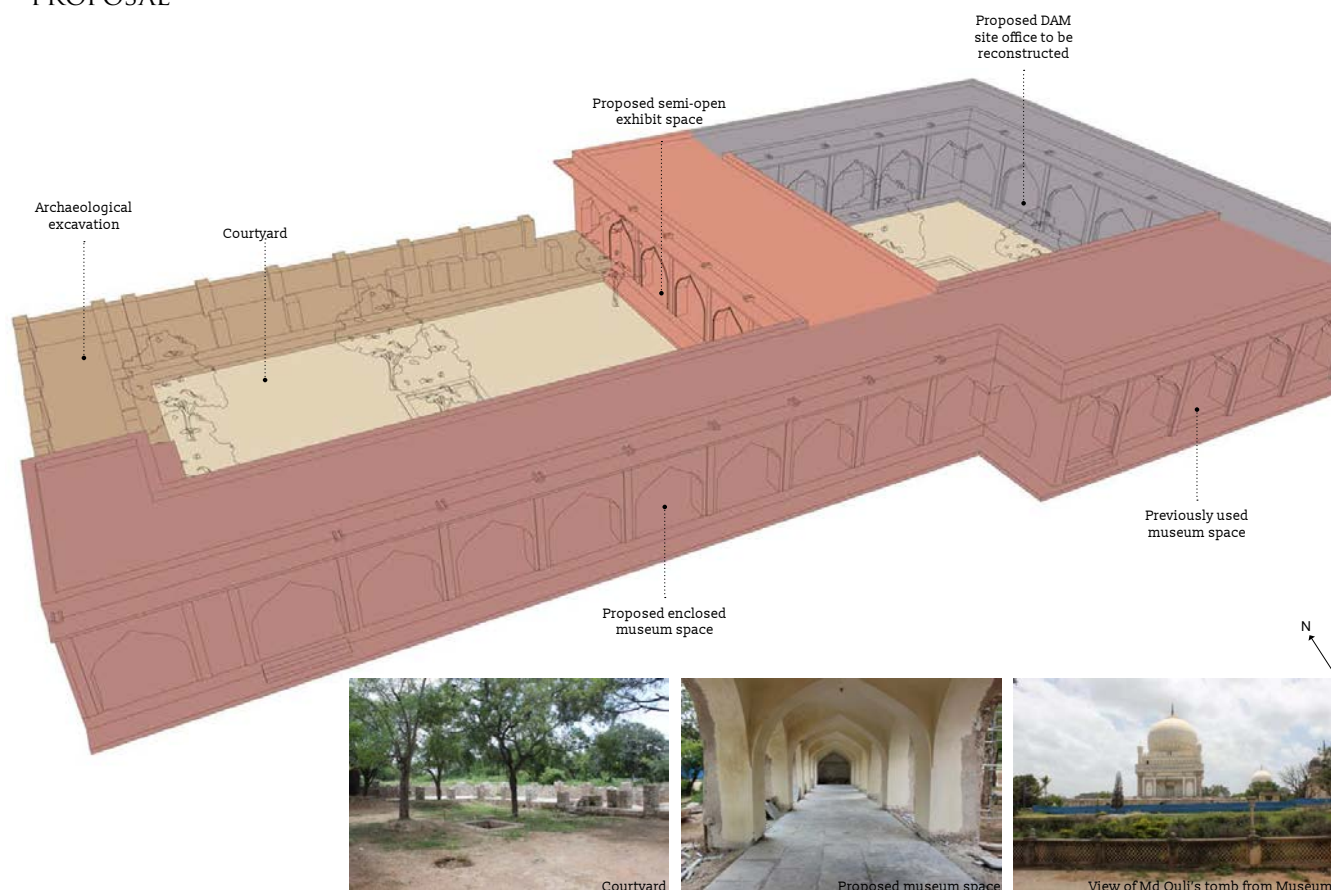
***Proposed Re-use of the area:***

The proposal for the museum development and office space in the adjacent sarai was prepared and shared with the Department of Archaeology and Museums, Government of Telangana for approval. Based on the approval of the proposed reuse of the sarai to the west of Hamam as a museum and Department office space, the remains of the corridor on the northeast section of the sarai were cleaned to reveal the bases. Columns and the arcade of the missing sarai corridor were built in stone masonry using lime mortar as per the existing evidence at site.

***Action Taken:***

- The roof of the arcade was capped with a flat roof instead of a dome, based on the recommendations of the Technical Committee.
- The arched corridor on north and east wing abutting the Hamam Baoli was reconstructed over the remains of the bases found, with arches spanning 3.0 metres in length and width. Each corridor consisted of 5 chambers. The reconstruction of the arches was completed in stone masonry using traditional lime mortar. Traditional honeycomb shuttering was fabricated by stone masons to support the arch stones for reconstruction of the "L" shaped arcade which had collapsed after 1870's.
- 8 inches thick stone beams were installed over the 3.5 meter wide reconstructed arcade on northern and eastern sides to span the roof. A low height masonry parapet wall was constructed in traditional lime mortar on the parapet edge along with the installation of projected stone eaves to match the original design of the facade. A 4 inch thick layer of base lime concrete was laid over the installed stone beams after necessary filling of the spaces in-between the beams

over which the final layer of lime concrete has been laid after the installation of stone eaves of the facade towards the central courtyard.

- The stone masonry parapet wall over the external facade of the north wing was constructed and stone water spouts were installed at equal intervals on the northern and eastern external parapets to drain rainwater away from the structure
- Finished plaster in traditional lime mortar was applied on the low height parapet wall above Hamam.
- Installation of steps using hand chiseled dressed granite blocks of appropriate colour inside the existing museum space was completed.
- Rear northern wall of Hamam and Sarai abutting the adjoining baoli was reconstructed using rubble masonry and traditional lime mortar.
- Over 1600 cubic feet of traditional lime concrete was laid on the reconstructed arcade in appropriate slope and stone water spouts will be installed on recently constructed low height parapet to channel rainwater away from the structure.
- Hand dressed granite blocks were installed inside missing portions at the southern arcade of Hamam matching the existing design of flooring layout.

### *Next Steps:*

Plaster repairs using rich lime mortar , lime punning and restoration of mouldings and ornamental bulbs on the arch crowns of reconstructed arcade will be followed by installation of 30 mm thick granite slabs to be laid inside the reconstructed arcade. Glass panels encased by steel sections of approved design by the technical committee will be custom fabricated as per the size of individual arches of the reconstructed arcade in 2019.

### **Impact:**

Reconstruction of collapsed portions and relaying of collapsed beams has not only ensured long-term preservation but also revived the original intent of the original builder. Future reuse of these reconstructed portions as an office cum library of the Department of Heritage would make this structure of pragmatic use. Installation of stone eaves would mitigate the effect of rainfall on the lower facades.





*(Left) Reconstruction of arcade using traditional honeycomb shuttering (Top right) Installation of stone beams on the reconstructed arcade's roof; (Bottom right) Ramming of the lime concrete laid on top of the stone beams*

CONSERVATION AND LANDSCAPE

# The Tomb Cluster

Located to the west of the mausoleum of Ibrahim Quli Qutb Shah stand a cluster of 13 monuments, smaller in scale but no less intricate or significant. Major conservation works continue to be carried out on these to restore the historic architectural character and remove inappropriate 20th century layers. Major works were also required on the landscape and large 20th century platform was dismantled to reveal the underlying natural rock features and the original monument platforms - which were subsequently repaired.

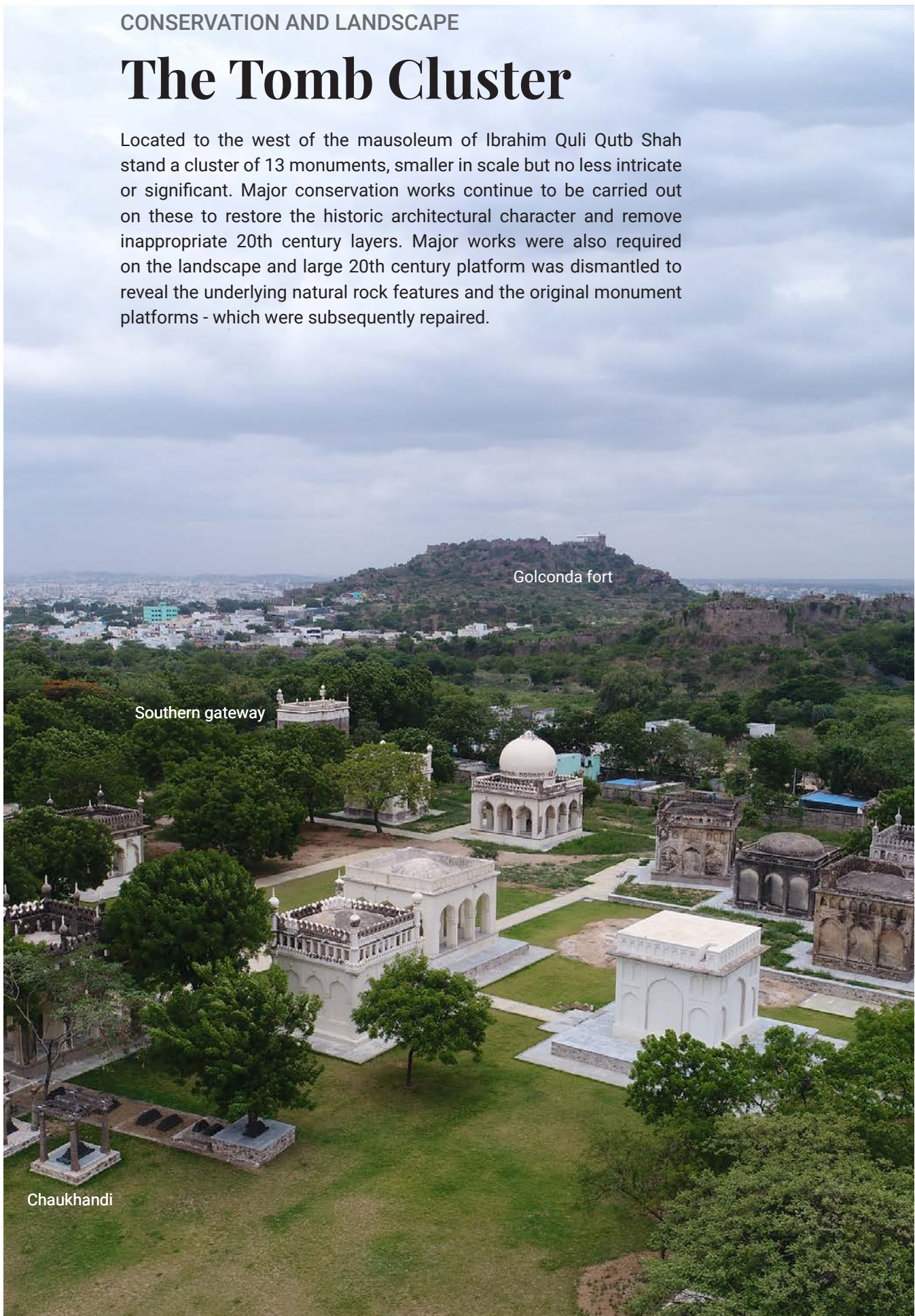

Golconda fort

Southern gateway

Chaukhandi

# 14 CONSERVATION OF Mausoleum 7

Located to the south-west of mausoleum of Ibrahim Qutb Shah, set abutting the cluster of 10 funerary monuments in the south-west quadrant of the site, works were commenced to arrest further deterioration. This included removing 20th century cement repairs, vegetation caused due to water seepage from terrace and restoration of ornamental plaster details and installation of stone flooring inside the mausoleum.

## *Action Taken:*

- Dismantling of cement plaster and flaked lime plaster from the parapet, external and an internal facade has been completed.
- Cement plaster on the external and internal surface has been replaced with rich lime mortar and finished with 1 mm thin layer of matured lime putty with added organic additives.
- Original ornamental details revealed on the removal of cement layers were restored matching the evidence at the site.
- Missing ornamental details on the tripartite arched bays structure have been completely restored as there was sufficient evidence available depicting the complete design profile.
- Dilapidated lime concrete on the floor of the internal mausoleum has been replaced by textured 30 mm thick granite stone slabs laid in formal layout and appropriate slope.
- Traditional lime concreting using small-sized aggregate was laid in appropriate slope on the terrace of the structure.
- Minor repairs were carried out on plaster details of the parapet level.
- Installation of projected water spouts on all four sides to drain water away from the structure on all four sides of terrace was carried out.

## **Impact:**

Conservation works on the structure have been completed and a plinth protection with immediate landscaping of its setting has been completed in 2018.



*Restoration of ornamental details in arch crowns*



*Repairs on external facades*

# 15 CONSERVATION OF Mausoleum 8

Located to the south-west of mausoleum of Ibrahim Qutb Shah, set abutting the cluster of 10 funerary monuments in the south-west quadrant of the site, works were commenced to arrest further deterioration. This included removing 20th century cement repairs, vegetation caused due to water seepage from terrace and restoration of ornamental plaster details and installation of stone flooring inside the mausoleum.

## *Action Taken:*

- Holes up to 1 meter deep were made during previous conservation works on the dome surface. These were filled with rubble stone and lime mortar to prevent further ingress of water.
- Dismantling of cement plaster and flaked lime plaster from the parapet, external and internal facade has been completed.
- Damaged external plaster on the dome was replaced with a 2-inch thick layer of lime mortar and finished with matured lime putty with organic additives.
- Missing and damaged portions of the external drum and the battlements on the parapet wall have been repaired and restored in lime mortar.
- Cement plaster on the external and internal surface has been replaced with traditional lime mortar.
- Damaged corner minarets on the parapet have been repaired by master craftsmen.
- Original ornamental details revealed on the removal of cement layers were restored matching the evidence at the site.
- Missing ornamental details on the tripartite arched bays structure have been completely restored as there was sufficient evidence available depicting the complete design profile.
- Dilapidated lime concrete on the floor of the internal mausoleum has been replaced a 4-inch thick layer of lime concrete and covered by textured 30 mm thick granite stone slabs laid in formal layout and appropriate slope.
- Traditional lime concreting using small-sized aggregate was laid in appropriate slope on the terrace of the structure.
- Minor repairs were carried out on plaster details of the parapet level.

*(Left) Repairs of rings situated above the dome; (Middle) Floral medallions being restored by master craftsmen; (Right) Installation of 30 mm stone inside the mausoleum*



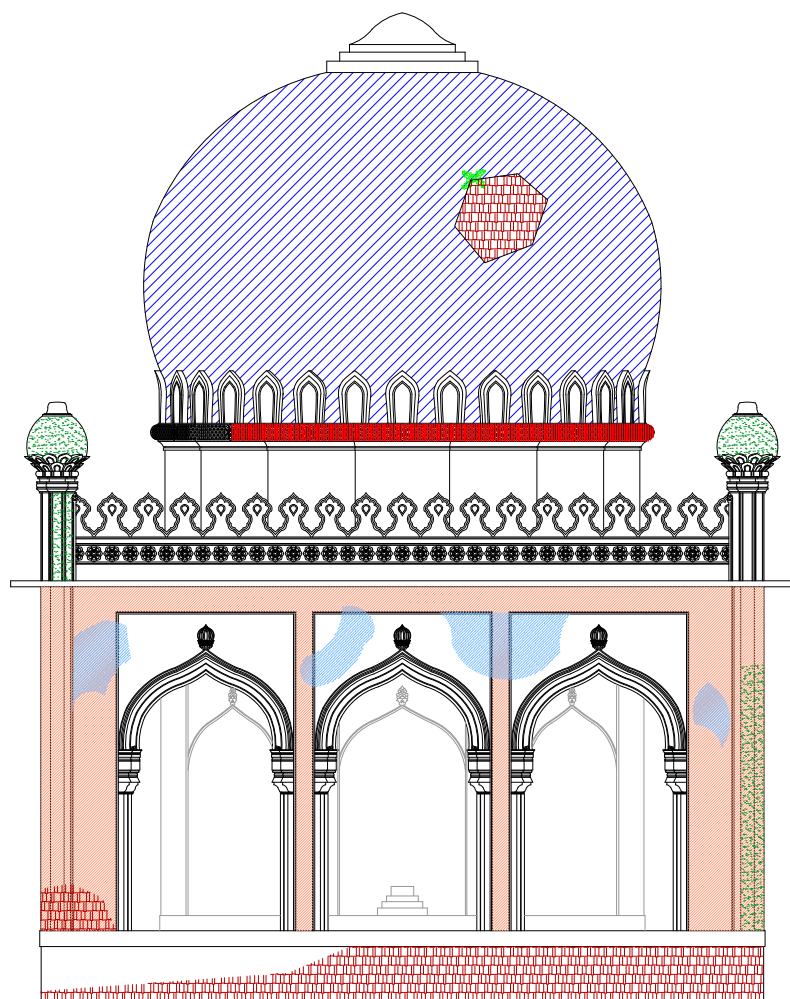

**LEGEND:**

**DEFECTS IN BUILDING / PLASTERED SURFACES**

- CRACKS IN THE PLASTER
- DECAYED PLASTER
- FLAKING OF FINISHING LAYER
- INTERVENTION
- MISSING MEMBERS
- NEW PLASTER
- EXPOSED MASONRY
- CEMENT PLASTER

**DECORATIVE PLASTERWORK**

- DECAYED PATTERN
- MISSING PATTERNS

**WATER PROBLEMS**

- WATER SEEPAGE
- WATER RISE

**SURFACE DEPOSITS**

- ALGAE
- BLACK CRUST
- GRAFFITI
- LIME WASH
- DEPOSITS
- VEGETATION

Qutb Shahi Heritage Park (Key Plan)

DEPT. OF ARCHAEOLOGY AND MUSEUMS, GOVT. OF TELANGANA

AGA KHAN TRUST FOR CULTURE

Qutb Shahi Heritage Park

Unknown Tomb- 8

Condition Assessment

North Elevation

Scale: 1:100

Date: Jan. 2017 Documented by: AKTC

QSHP/CA/T08/04

Condition assessment of north elevation of Mausoleum 8

**Impact:**

Conservation works on the structure have been completed and a plinth protection with immediate landscaping of its setting has been completed in 2018.

Completion of conservation works will lead to long term preservation of the structure along with reviving architectural integrity.

# 16 ANASTYLOSIS OF Chaukhandi

Located to the south of the mausoleum of Jamshed Quli Qutb Shah, is an erect chaukhandi, a trabeated structure with stone beams supported by brackets and placed on beams. Similar stone elements belonging to collapsed chaukhandi were found lying on the ground. Archival images from the 1870's show the collapsed structure standing. A detailed visual survey of individual pieces was conducted followed by individual documentation of the stone pieces. This resulted in revealing of cracks on several pieces. Anastylosis, careful reassembly of the individual disassembled stone architectural elements, was carried out digitally using a comparative study with the existing erect chaukhandi and archival images.

### *Action Taken:*

- In view of the partly missing column piece, a stone piece of matching profile with the broken column was hand carved and fixed.
- All the broken beam sections were retrofitted with stainless steel dowels along with epoxy resin and left to set for a couple of weeks before erection.
- The base masonry surrounding the grave platform was repaired and missing edging stone blocks were reinstated.
- Careful erection of individual columns in plumb was followed by meticulous placement of brackets and beams in their original positions.
- 30 mm thick granite stone slabs have been laid on the periphery of the grave in an appropriate slope to mitigate rainwater seeping into the foundation of the structure.

### *Next Steps:*

Cracks on the beams anchored with stainless steel dowels are being periodically monitored.

### **Impact:**

Conservation of chaukhandi based upon anastylosis of disassembled stone architectural elements has given a new lease of life for the collapsed structure and added a new dimension to the conservation methodology adopted to restore historic monuments at the tomb complex.

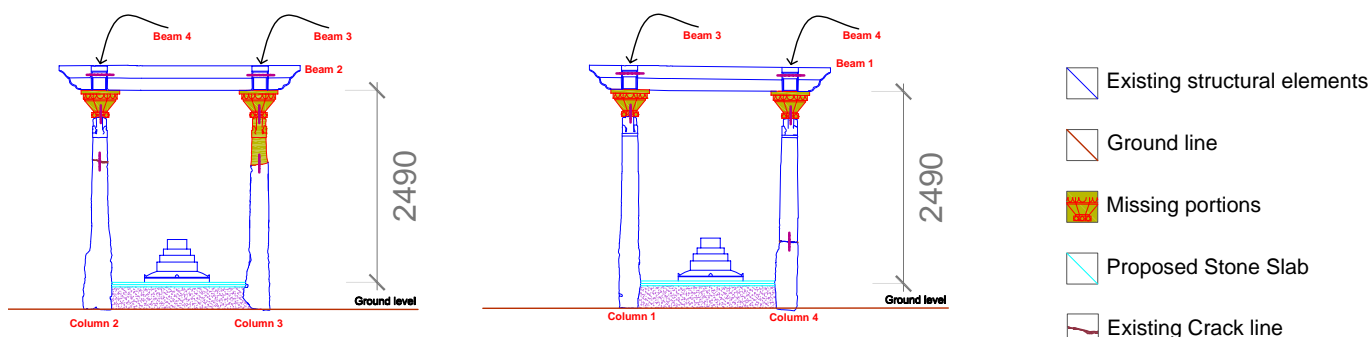

Anastylis - Southern Facade

Anastylis - Northern Facade

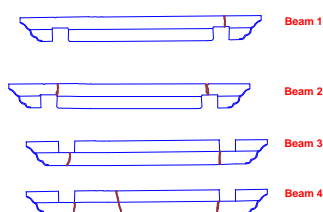

Documentation of beams

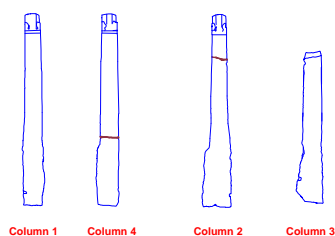

Documentation of columns

*Detailed documentation of individual beams and columns marking the cracks for installation of stainless steel dowels for retrofitting*



*A hand carved stone piece of matching profile was retrofitted with stainless steel dowels along with epoxy resin*



*The collapsed pieces were reinstated in their original position*

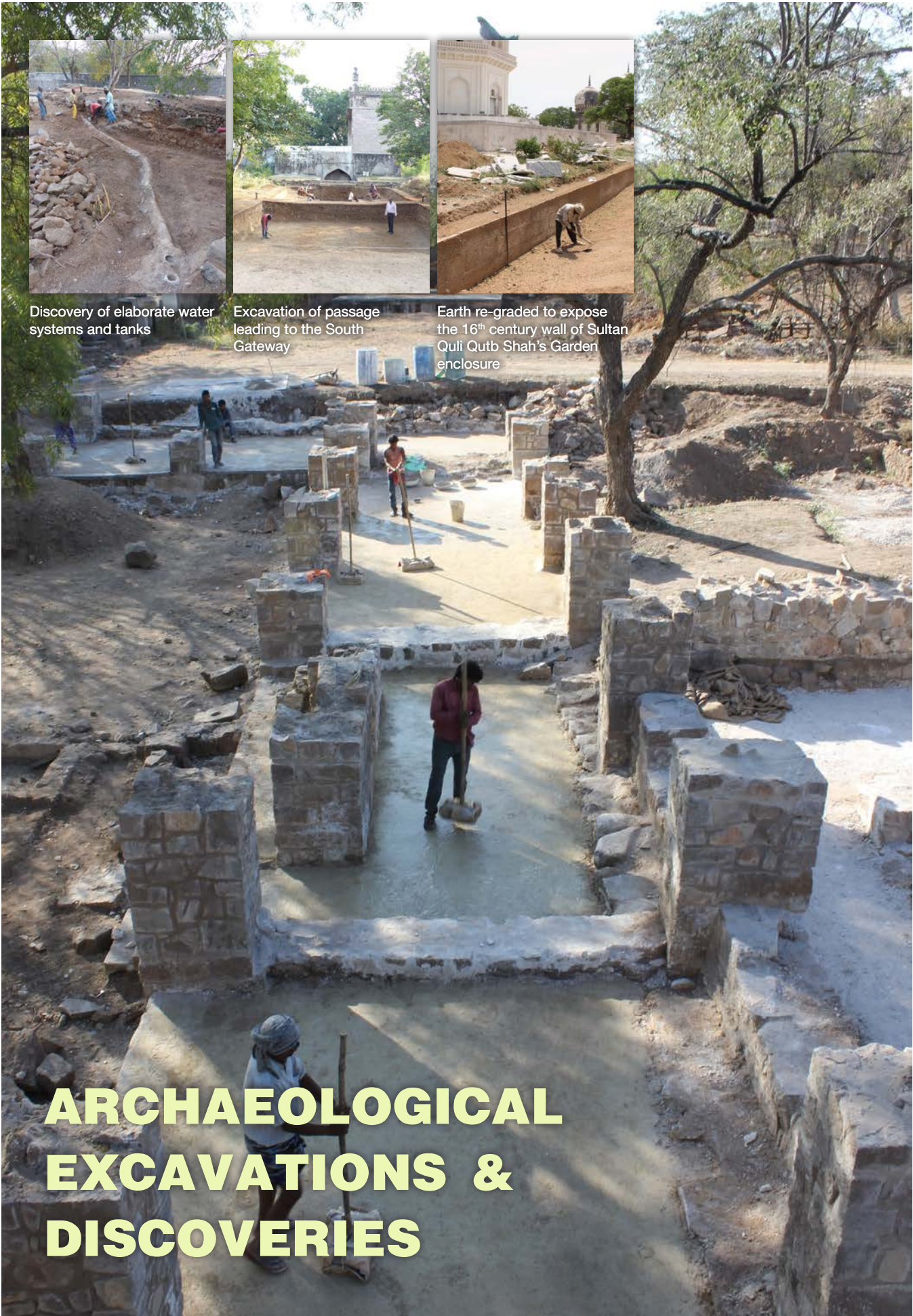

Discovery of elaborate water systems and tanks

Excavation of passage leading to the South Gateway

Earth re-graded to expose the 16<sup>th</sup> century wall of Sultan Quli Qutb Shah's Garden enclosure

# ARCHAEOLOGICAL EXCAVATIONS & DISCOVERIES





# 17 CONSERVATION OF Southern Gateway

Arched Southern gateway was built in the center of the southern garden enclosure wall originally built around Mausoleum of Ibrahim Quli Qutb Shah to serve as an entry from Golconda Fort– for the burial procession. The full extent of the arched opening was revealed during excavation works carried out from 2014-2016.

Made up of stone masonry in lime mortar, the gateway has a high arched opening and covers an area of 14 m by 10.7 m. The arched opening is framed by a rectangular moulding and is flanked by two highly ornamental lime stucco medallions, one on each side of the archway and a flower bud shaped arch-crown. The gateway is abutted by two high plinths – one on each side, each high plinth having an arch-shaped niche carved into it. Above the southern gateway is a mosque.

There were visible signs of deterioration with soot covering the walls and ceilings of multiple chambers inside the gateway. Original stucco on the ceiling was partially missing and original surface flaking at multiple spots. In addition, dumping of rubble and earth had drastically altered the original floor levels inside the structure.



Resotoration of facade



Revealing original levels of stone door frame



Construction of retaining walls

### ***Action Taken:***

- During the clearing of the vegetation overgrowth, and base documentation of the structure, it was discovered that the plaster condition on the facades was decayed, with the presence of exposed masonry, excess earth and presence of bats.
- The internal surface of the southern gateway was damaged with exposed stone masonry and ornamental details missing in major portions. Lime plastering of the walls was completed in three bays to the north, and details including missing arch crowns, arch mouldings, and ceiling medallions were restored.
- During the excavation of the excess earth, the original floor level of the south gate including the ornamental detail at the stone threshold of the gate was uncovered.
- Plaster repairs on the walls and ceiling of the structure were carried out in rich lime mortar and all the ornamental details were restored meticulously
- Excess earth and rubble were manually removed to reveal the original floor levels and subsequently, traditional lime concrete was laid to act as the base for laying of stones.
- 30 mm thick slabs of granite were laid in appropriate slope inside the structure to make it withstand the visitor tourist footfall.
- The original ramp connecting mausoleum of Ibrahim Quli Qutb Shah to the arched gateway was repaired with the construction of partially collapsed ashlar masonry walls and laying of concrete in slopes predicated by landscape master plan to make pedestrian possible for the visitors.
- 50 mm thick slabs of tandur stone were laid in approved layout and appropriate slope over the ramp.

### ***Next Steps:***

Finishing of restored internal plaster and stucco ornamentation has to be finished using a thin coat of lime putty mixed with organic additives

### ***Impact:***

The ongoing effort allows an opportunity to restore the southern gateway to the tombs to be restored as per the intention of the original builders and reinstate the original appearance. Conservation of ornamental stucco both on the internal and external facades has restored the authenticity of material, form, and design of the southern gateway. It is hoped that with eventual removal of encroachments on the southern edge, the arched gateway could once again be used by visitors coming from Golconda to the Qutb Shahi Heritage Park.

# 18 CONSERVATION OF Mosque above Southern Gateway

Located above the Southern Gateway of Qutb Shahi Heritage Park, conservation works began on the structure in 2017 and were completed in 2018.

In order to ensure long term preservation, 20<sup>th</sup> century cement layers from the façade and roof were carefully removed and replaced with lime mortar. The vegetation growth was carefully removed and water spout opening on the western facade were cleared. Missing or partially damaged details were repaired with traditional lime mortar by master craftsmen. Missing kanguras and minarets were reconstructed as seen in the archival images.



*Before Conservation*



*After Conservation*



*Before Conservation*



*After Conservation*

**Action Taken:**

- The highly ornamental minarets on all four corners were restored by master craftsmen using traditional lime mortar.
- The internal surface was found to be severely damaged due to water seepage from the terrace above with visible vegetation growth on the external surface. Vegetation was removed from the roof and the external surface.
- Existing terrace showed evident signs of water leakage and it had to be dismantled. Terrace was laid with traditional lime concrete in appropriate slope and multiple stone water spouts were installed on northern, western and southern sides to channel rainwater away from the structure.
- Damaged and missing portions of the intersecting arched band above the parapet were restored with stone masonry and finished with lime mortar as per existing evidence. Ornamental bands, arched openings and blind arches on the parapet wall were repaired. Missing and damaged details were repaired and restored as per existing evidence.
- Missing black basalt edging elements at the column bases were reinstated, and 30 mm thick granite flooring was laid in the internal chamber of the mosque as per the approved plan.
- Intricate incised lime stucco work on the eastern facade below the chajja was carefully repaired in damaged portions and finished with lime punning.
- Missing details and damaged surface and on the internal facade were repaired with traditional lime mortar.
- 30 mm thick granite stone slabs were installed in the forecourt of the mosque and inside the mosque as per the approved layout and appropriate slope.
- Inspection at the forecourt of the mosque revealed the existence of a rectangular tank around the foliated dressed stone Wazu tank. During this process, three historic terracotta pipes were revealed on dismantling of the 20th century cement concrete layer. These were documented in detail. 8" thick hand-chiseled dressed granite stone edging was installed around the 'Wazu' tank to highlight this important architectural feature.
- Irregular stone steps added later on the eastern facade were dismantled. Subsequently, hand chiseled dressed stone blocks of appropriate width were installed aligning with the arcade above.
- Traditional lime plaster was applied on the sides of the steps and the east facade of the plinth.
- Battlements surrounding the forecourt of the mosque were found in a dilapidated condition. Their profiles were restored by master craftsmen using rich lime mortar and finished with 1mm thin layer of lime putty mixed with organic additives.



Restoring the minar



Restoring parapet details



Final lime punning

### Impact:

To ensure long term preservation, 20th-century cement layers from the roof were carefully removed and replaced with lime mortar. Conservation effort allowed an opportunity to restore the mosque and reinstate the original appearance.

This arrested the deterioration to prolong the life of the structure as a result of effective water drainage. During this process, several original architectural elements were revealed and carefully restored.

Conservation of ornamental stucco both on the internal and external facades as per the intention of the original builders and in turn has restored the authenticity of material, form, and design of the mosque.



*(Left) Restoration of lime stucco details on the facade; (Top Right) Installation of granite stone edging around the 'wazu'tank; (Bottom Right) Installation of hand chiseled dressed stone steps*

# 19

SUPPORTED BY SWADESH DARSHAN GRANT

## Landscape Restoration

Historic evidence suggests the existence of gardens around the mausoleums at Qutb Shahi Heritage Park. With the discovery of the 16<sup>th</sup> century enclosure wall and visible remnants of an elaborate arcade established the existence of a historic garden-tomb enclosure. The landscape development of the complex was carried out following a series of analytical studies such as slope analysis, existing vegetation, and remnants of the historic landscape. Landscape works have been supported by the Swadesh Darshan Grant from Ministry of Tourism, Government of India.

Upon commencement, it was found that the earth levels had been altered by dumping excess earth at places up to 60 cm deep - leading to water stagnation near the plinth of the monuments. Similarly, existing 8 cm thick granite plinth protection was re-laid after lowering the levels to expose the original hand chiseled stones of the plinth walls of the enclosure walls surrounding the gardens of Mausoleum of Sultan Quli Qutb Shah. Pathways connecting the major monuments were constructed linking the individual mausoleums situated inside the arcaded enclosure. Gardens were established as per appropriate gradient to drain away the rainwater towards the baolis situated nearby. To ensure adequate surface water runoff and water harvesting, subterranean trench drains with catch basins have been constructed in strategic locations channeling rainwater to the nearby existing Baoli.

Landscape development has been carried out in five different zones; enclosure of Sultan Quli Qutb Shah, enclosure of Ibrahim Quli Qutb Shah, the forecourt of Mausoleum of Muhammad Quli Qutb Shah, ecological Zone to the west of Mausoleum of Jamshed Quli Qutb Shah and ecological Zone to the east of Idgah.



*Dressing of earth for laying of grass*



*Conservation of the monuments is being coupled with sensitive landscaping their immediate surroundings; creating a historically appropriate setting. Landscape development included the removal of modern interventions, restoration of original earth levels, laying of stone pathways and plinth protection around the monuments.*

**Action Taken:**

- Subterranean trench drains with catch basins were constructed to drain water from the soft surfaces towards the nearest baoli situated to the west of mausoleum of Jamshed Quli Qutb Shah on edge of enclosure of Sultan Quli Qutb Shah. Similar trench drains for channeling of rainwater towards Idgah baoli was constructed inside the enclosure of Ibrahim Quli Qutb Shah.
- Three masonry tanks were revealed during removal of excess earth. Debris was removed from these tanks and repaired with random rubble masonry using lime mortar and lined with 100 mm thick granite stone edging on top to ensure long term preservation. Two of these were situated inside the garden enclosure of Sultan Quli Qutb Shah and the third tank was situated inside the garden enclosure of Ibrahim Quli Qutb Shah.
- Steps made in hand-chiseled dressed granite was installed as per landscape master plan leading to eastern axial pathway aligned with the mausoleum of Sultan Quli Qutb Shah. The pathway originating from the eastern axis of Sultan Quli's mausoleum was extended up to the southeastern edge of the mausoleum of Mohammed Quli with connections to plinth protection on the north side.
- Plinth protection at the mausoleum of Muhammad Quli Qutb Shah was laid with access steps to the crypt and the upper plinth of the mausoleum on the north side, on the west side of the mausoleum, the mausoleum crypt and the area between the 16<sup>th</sup> century enclosure wall. The flooring was carried out using 100 mm thick granite stones with a shallow drain in the middle to allow the surface water to directed towards the catch basin eventually leading to the Idgah Baoli through the trench drains.
- 5 feet wide plinth protection was constructed around the cluster of unknown monuments situated to the south-western corner of the garden enclosure of Ibrahim Quli Qutb Shah. Construction of 7 feet wide connecting pathways was carried out at the same time.



*Steps installed for access*



*Repair of the tank revealed*



*Plinth protection around mausoleum 14*



*Laying of pathways*



- Excess earth dumped in 20<sup>th</sup> century in-between the tombs 15, 13 and 14 were manually removed to reveal the original rock profile of the area. Rock was retained during the landscape works with the plinth protection and pathways built in a contextually appropriate manner.
- Plinth protection around the mausoleum of Ibrahim Quli was constructed in a manner to accommodate the grave platforms situated on the western side of Ibrahim's mausoleum. Pathways connecting the mausoleum of Ibrahim Quli Qutb Shah to the southern axial pathway on the west side were built.
- Removal of the filled in the earth near the southern gateway of enclosure of Ibrahim Quli Qutb Shah revealed the extent of retaining walls surrounding the access. Significant level difference of 3 meters was mitigated through the design of ramp, where the ramp was branched out on both ends to join the southern pathway, thus negotiating a level drop of over 3 meters with an appropriate slope to enable disable access.
- Retaining walls in ashlar masonry were built along the edges to support the surrounding earth. Concrete was laid on the ramp in appropriate slope to enable disabled access till the Southern Gateway.



*Granite stone coping laid on the raised plinth wall*



*Trench for water drainage*



*Restored landscape*

### *Next Steps:*

- A detailed landscape plan was developed for the area in between the Hamam including the adjoining Sarai and the mausoleum of Mohammed Quli Qutb Shah.
- Plinth protection on the south side of the Hamam and the Sarai has been planned to be built with platform and grass slopes along the edge thereby maintaining a drop of at least 10cm below the original flooring level of the monument and restricting the surface water to enter into the structure. Other proposals include a platform built in 100 mm thick granite for the entrance to the Hamam, the development of the Sarai to house the offices as well as an exhibition space and pathways in tandur connecting the entire garden area to accommodate the varying levels with seating areas and plantation. Development of a small vineyard has been proposed in one portion of the garden space based on an archival image from 1860.
- Proposed landscape works on the remaining areas in Phase –I shall be completed as per the master plan and works shall commence on Phase – II of the complex including the Hamam forecourt and the area around the mausoleums of Taramati, Premamati, Sultan Mohammed Qutb Shah, Hayat Bakshi Begum, Hakims and Commander.

### **Impact:**

Restoration of landscape as per the landscape master plan has revived the grandeur of the royal necropolis and ensured long term preservation thus reviving the intention of the original builder and making the space pragmatically green and useful for the local communities and visiting public.

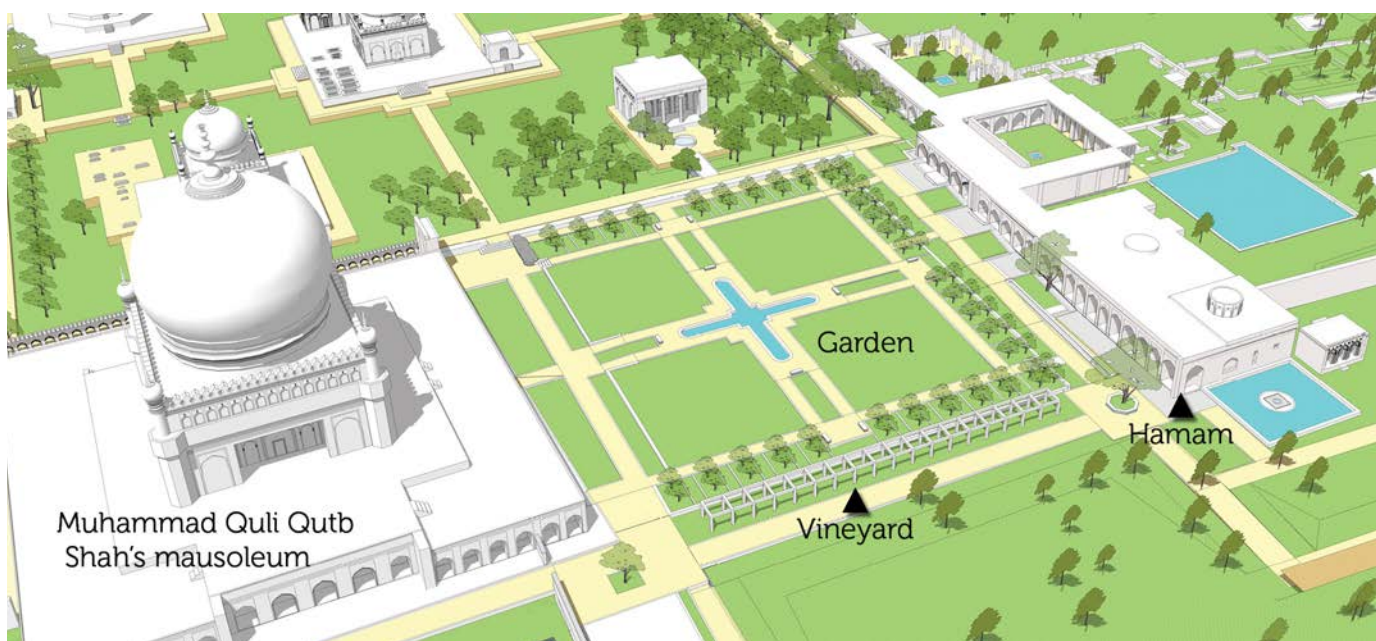

*Proposed landscape plan for Muhammad Quli Qutb Shah's forecourt*



Palash (*Butea monosperma*)



Chikoo (*Manilkara zapota*)



Yellow Trumpet Tree (*Tabebuia aurea*)



Sitaphal (*Annona squamosa*)

## Tree Mapping

Qutb Shahi Heritage Park spread over 108 acres is comprised of a diverse range of habitats that support a remarkable numbers and species of plant life and birds.

All the trees within the Qutb Shahi Heritage Park have been mapped and marked on the map. Basic information on every tree comprising of size of canopy, width of girth, height, species and nativity has been tabulated.



Jacaranda *mimosifolia*



Gulmohar (*Delonix regia*)



Coconut (*Cocos nucifera*)



Goolar (*Ficus racemosa*)



African Tulip (*Spathodea campanulata*)



Babul (*Vachellia nilotica*)



Champa (*Plumeria rubra*)



Nile Tulip (*Markhamia lutea*)



Garlic Pear (*Crateva religiosa*)



Bael (*Aeglae marmelos*)



Red Cotton Silk (*Bombax ceiba*)



Banyan (*Ficus Bengalhinis*)



Laying of grass



Planting new saplings



Landscape berm

# 20 LANDSCAPE DEVELOPMENT

## Plantation

### *Action taken:*

- A landscape berm spanning over 100 meters was made by dumping of earth along the periphery of the south-west quadrant to visually and physically delineate the landscape area and the buffer/ ecological zone. This would disallow visitors to enter into the ecological zone.
- Local grass, Fiscue, was laid on all the exposed earth within the enclosure wall. The grass laying was extended beyond the 16<sup>th</sup> century enclosure wall to the south side covering the west of mausoleum of Ibrahim Quli Qutb Shah; around the Tombs 14, 15, 16, 17 and 18.
- 30 labourers were engaged for over 60 days to ensure that the earth bed is properly prepared; grass was mowed and watered regularly. Around 16000 square meters of grass was laid in the 1st Phase of the landscape development in the complex.
- Over 1600 Saplings of local tree species have been planted in various parts of the complex. Guava (*Psidiumguajava*) and Kamrakh (*Averrhoa carambola*) have been planted on the northern and western edge of the 16<sup>th</sup> century enclosure wall. To the east of mausoleum of Hayat Bakshi Begum, Custard apple (*Annona squamosa*) saplings have been planted.
- Similarly, saplings of mango (*Mangifera indica*), Chikoo (*Manilkara zapota*) and other fruit-bearing trees were planted in the Idgah area after removal of the invasive subabool trees from the area.

# 21 Swadesh Darshan Grant

The Telangana State Tourism Development Corporation (TSTDC), in technical consultation with the Aga Khan Trust for Culture, submitted a detailed project report (DPR) to the Ministry of Tourism, Govt. of India for the Development of Heritage Circuit in Hyderabad under the Swadesh Darshan scheme. The proposal envisaged the development of landscape and other visitor facilities at the Qutb Shahi Heritage Park, Paigah Tombs, Hayat Bakshi Begum Mosque and Raymond's Tomb.

## Action Taken:

- In February 2017, the Central Sanctioning and Monitoring Committee (CSMC) for the Swadesh Darshan Scheme in Ministry of Tourism approved the project and a total amount of 99.42 crores was sanctioned for the project which included 42 crores for the construction of the proposed Interpretation Centre at the Qutb Shahi Heritage Park. As per the approval, TSTDC shall be the implementing agency and the Secretary, Youth Advancement Tourism and Culture; Govt of Telangana would be the nodal officer for the grant.
- The 1<sup>st</sup> part of the grant was released in June 2017 to allow the commencement of the proposed works at the four sites. Subsequent discussions were held with the Government of Telangana in 2017-18 and it was agreed upon the following:
  1. Aga Khan Trust for Culture (AKTC) would act as Project managers for the grant.
  2. In lieu of the underlying archaeology in the core heritage zone of the Qutb Shahi Heritage Park and Paigah Tombs, the landscape development works – plinth protection abutting monuments, connecting pathways, toe walls, retaining walls, necessary earth grading etc., as per the approved landscape master plan would be executed by AKTC in consultation and agreement with the Department of Heritage Telangana – the custodian of the site.
  3. AKTC would provide the necessary technical drawings, specifications, and estimates for the proposed parking, amphitheater, front, and rear boundary wall, peripheral road, public amenities and street furniture at Qutb Shahi Heritage park to TSTDC for the tendering the works. It would also provide all the technical details for the proposed development of landscape, parking and public amenities to TSTDC for the tendering of proposed works at the Hayat Bakshi Begum Mosque and Raymond's Tomb.
  4. A presentation on the proposed Interpretation Centre at the Qutb Shahi Heritage Park and the development of landscape and public amenities would be made to the existing Heritage Committee constituted by the Department of Heritage Telangana for an in-principle approval.
- AKTC, along with the Department of Heritage Telangana, made a presentation to the Heritage Committee in November 2017 on the proposed scheme of development for all the four sites under the grant. The Heritage Committee agreed in principle for all the development works. However, the Committee was not in approval of the proposed plan of the Interpretation Centre owing to the size and proposed facilities and suggested that a design brief be prepared and approved from the Committee based on which the design would be developed and approved. A detailed Architectural Design Brief was developed for the Interpretation Centre that intended to complement the overall vision for the Centre and detailed a program of building attributes, building functions, area requirements, technical requirements, budgets, and other relevant details.
- It was agreed in the Project Technical Committee Meeting headed by the Secretary Tourism to the Government of Telangana to invite selected Architects for the concept design of the Interpretation Centre proposed at the Qutb Shahi Heritage Park.

- Tender documents were submitted by AKTC to TSTDC for the proposed development of Parking, Amphitheatre, front and rear boundary wall and the peripheral walkway of the Qutb Shahi Heritage Park. Similar documents for the development of landscape and public amenities at Hayat Bakshi Begum Mosque and Raymond's Tomb were submitted for calling of tenders by TSTDC.
- Construction works were commenced on the amphitheater, parking, rear boundary wall and peripheral walkway by the contractor selected by TSTDC through a tender process. Works have also progressed at the Hayat Bakshi Begum Mosque and Raymond's Tomb by the selected contractor. AKTC has facilitated the commencement of all the works and is monitoring the works regularly.

### *Next Steps:*

- Selected Architects for the concept design of the Interpretation Centre proposed at the Qutb Shahi Heritage Park shall be invited to present their proposals to a High Level Committee formed by the Department of Heritage Telangana, based on which the final design and the architectural firm would be selected for further development and based on the final selected design, tenders would be called by TSTDC (Telangana State Tourism Development Corporation) for construction.
- Construction works on the amphitheatre, parking, rear boundary wall and peripheral walkway shall continue at the Qutb Shahi Heritage Park. Works at the Hayat Bakshi Begum Mosque and Raymond's Tomb shall also continue.
- Landscape Development works at the Paigah Tombs complex shall also commence.

### **Impact:**

Development of landscape works and visitor facilities shall further help in the development of the Heritage Circuit in Hyderabad and provide a world class experience to the visitors.





Hayat Bakshi Begum's Mosque



Paigah Tombs



Raymond's Tomb



## 22 CONSERVATION AND LANDSCAPE RESTORATION

### Paigah Tombs

The Paigah tombs are the resting place of the Paigah family of Hyderabad. Known for their undoubted loyalty to the Nizams, the Paigahs were one of the most influential and powerful nobles of the time. Their affluence is reflected in the intricately carved marble tombstones. Built in the 18th century, the small complex of the Paigah tombs is a unique ensemble with no comparative site anywhere in the world boasting of the incredible craftsmanship employed by the Hyderabad craftsmen. The structures boast of fine lattice screens and incised plasterwork – both in lime mortar.

The Paigah Tomb Complex houses several tomb enclosures, a mosque, a water body, and an entrance gateway. These 200 years old tombs are known for their architectural excellence as shown in their craftsmanship of highly intricate surface ornamentation. These tombs are made out of lime mortar with beautiful incised plasterwork and lattice screens. Most of the tomb enclosures are open-to-sky with intricate carvings on the marble and jade tombs.

As part of the Swadesh Darshan Scheme, the Department of Tourism, Telangana, has proposed to develop the area's landscape. Its proposed components include landscaping, illumination, information signage, and a ticket counter. It has also proposed the setting up of an exhibition for the site. Other tourist/ visitor facilities including drinking water, toilets, solid waste management, and parking will also be incorporated for tourists.



### *Action Taken:*

- An extensive topographical survey was carried out of the Paigah Tombs Complex as well as the surrounding areas.
- Stucco samples were created of the intricate ornamental lime stucco panels present on the majority of tombs inside the tomb complex.
- 1mm thick terracotta tile samples were created replicating the existing terracotta tiles that make up the framework of the existing lattice screens. A true size mockup matching a preselected existing lattice screen will be fabricated at the site with the final lime finish matching the existing evidence at the site.
- A detailed 3-dimensional laser scan of the entire complex was undertaken to assess the current condition of the mausoleums. High definition data procured from this technique will aid in the preparation of precise architectural documentation and detailed condition assessment marking the extent of damage on individual tomb structures.



Condition assesment of Mausoleum of Ghansimiyan

***Next Steps:***

The conservation and landscape works shall commence beginning from the Mausoleum of Ghansimiyān and the Samakhana located to the west of the Mausoleum. Thorough documentation and condition assessment of all the structures within the Paigah Tombs Complex shall be undertaken. The landscape works shall be carried out under the Swadesh Darshan Grant from the Government of India. These will include the construction of pathways as per the landscape master plan.

**Impact:**

To ensure long term preservation, 20<sup>th</sup> century cement layers from the mausoleums shall be carefully removed and replaced with lime mortar. Conservation works undertaken shall include the restoration of damaged intricate lattice screens, removal of 20th-century cement layers, repairs in lime mortar, lime punning, and installation of stone water spouts on terraces of individual tomb structures. Conservation of ornamental stucco and lattice screens both on the internal and external facades as per the intention of the original builders shall, in turn, restore the authenticity of material, form, and design of the mausoleums.



*Before Conservation: Monuments around the Paigah Tombs complex*



Mosque at the Paigah Tombs complex



Intricate lime stucco details

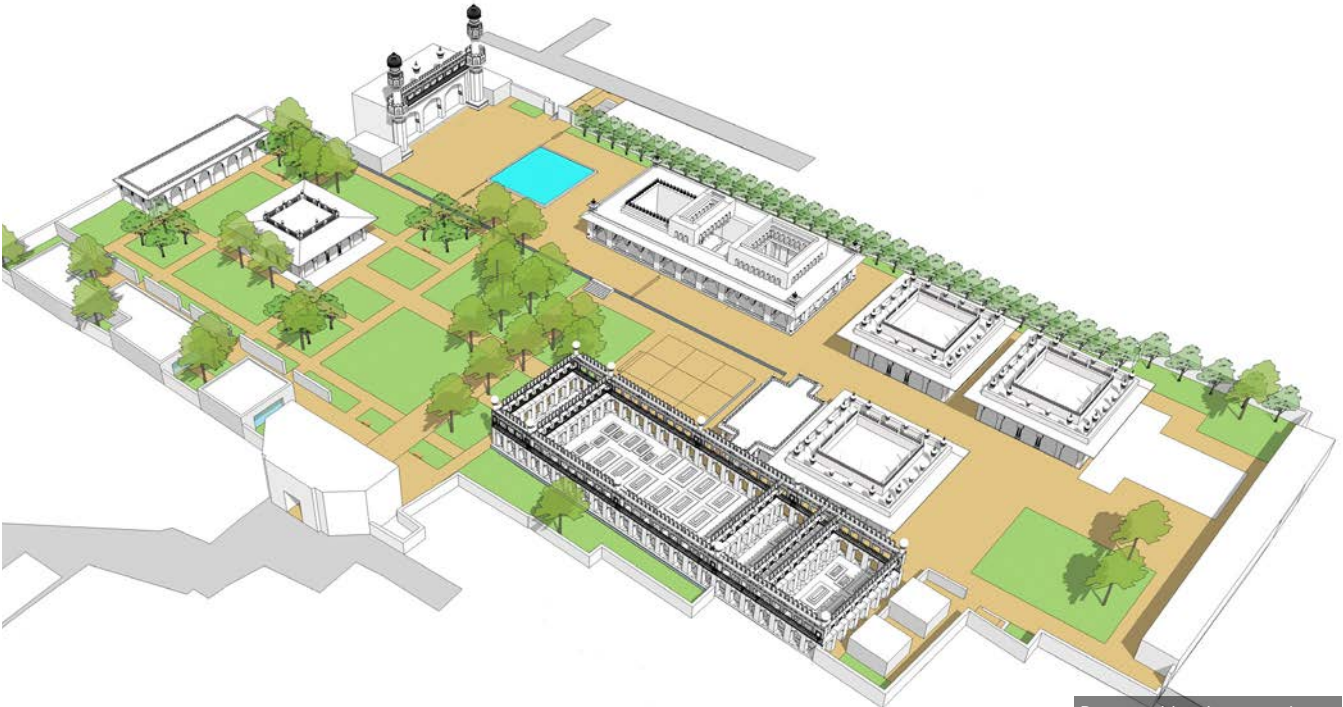

Proposed landscape scheme



Gravestone inscribed with embellishment in carved marble

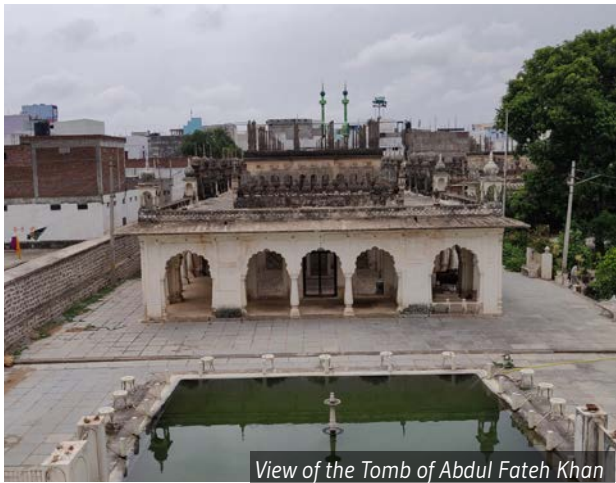

View of the Tomb of Abdul Fateh Khan

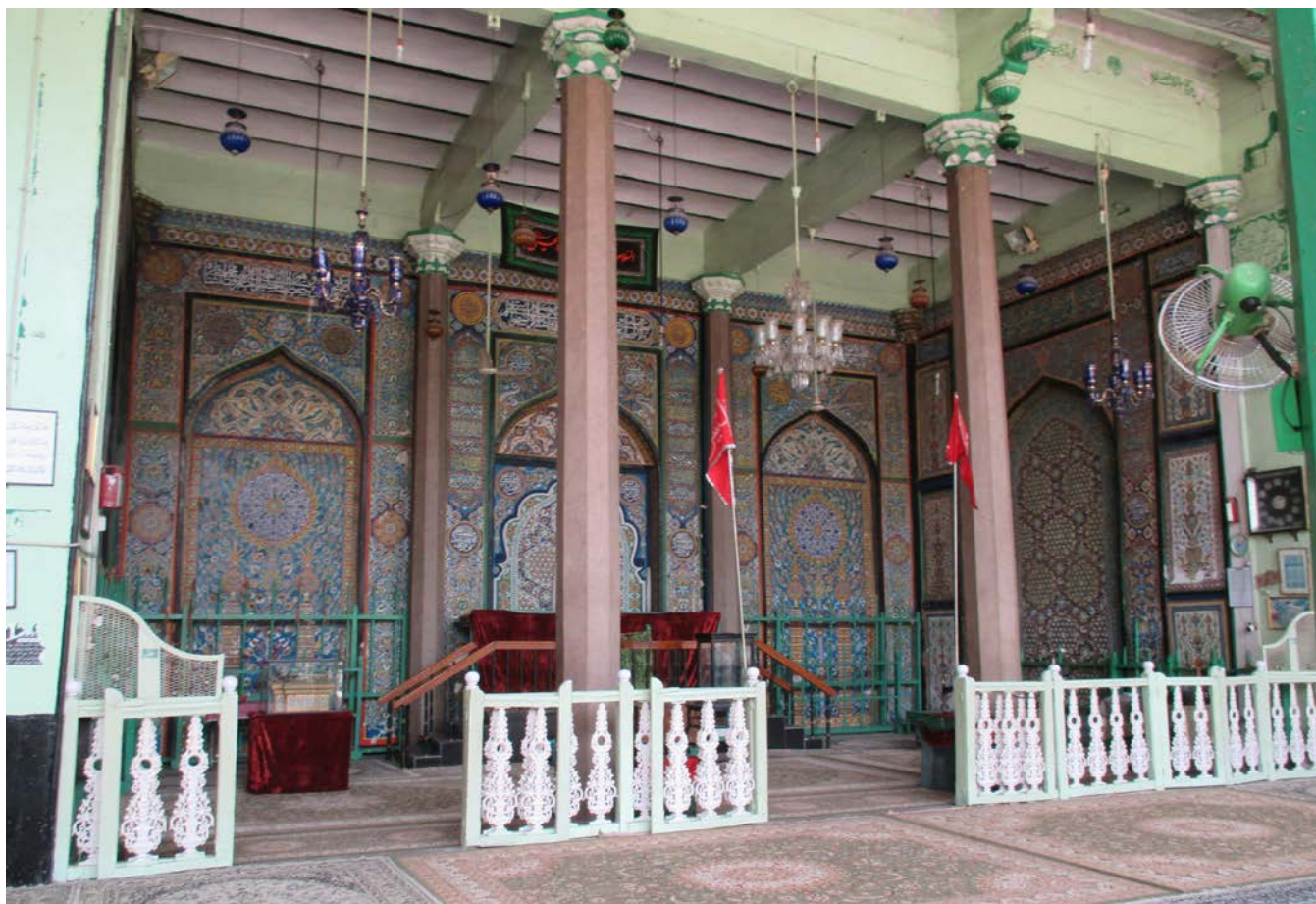

## 23 CONSERVATION OF Badshahi Ashoorkhana



*Tiled arched panel*

Constructed in c.1595, it is the largest of all ashurkhanas built by the Qutb Shahis during the reign of Muhammad Qutb Shah.

Measuring nearly 40 yards by 30 yards and 12 yards in height, the flat roof is supported by monolithic stone columns. Five recessed arches, 3 on the western wall and one each on either side are encrusted with exquisite enameled inlay tile work, which was installed by Persian craftsmen during the reign of Abdullah Qutb Shah in 1611. The tilework consists of highly refined geometric, floral and arabesque designs in a varied colour palette consisting of blue, white, yellow, green and terracotta.

Three of the five tiled arched panels are noteworthy. One represents a giant alam, a religious metal standard symbolizing the battle standards carried by Hussain and his followers at Kerbala, second panel has designs of staggering hexagons containing jewel like shapes connected by grand arabesque swirls. On a third panel, a massive pot-of-plenty overflows with twisting and turning vegetation.

Emergency repairs were carried out the structure upon request of the Department of Heritage Telangana who had been approached by the members of the community to carry out emergency repairs as the roof was leaking and seepage of water from the western wall was damaging the 400-year-old enameled tiles. The roof and external walls were repaired in 2018 mitigating future deterioration.

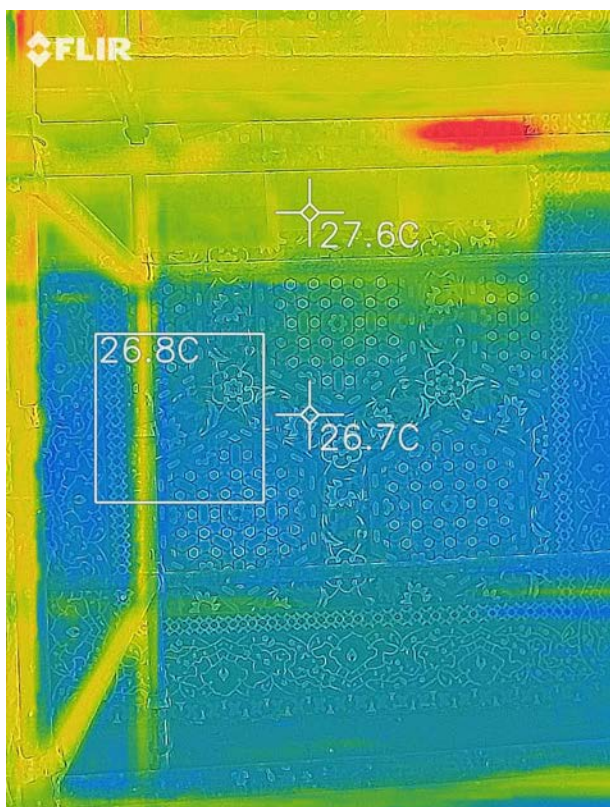

Thermal imaging using a thermal sensing camera, which helps detect areas of moisture. These readings will be taken over a course of a year at different seasons to understand impact of moisture/dampness on the tiles.

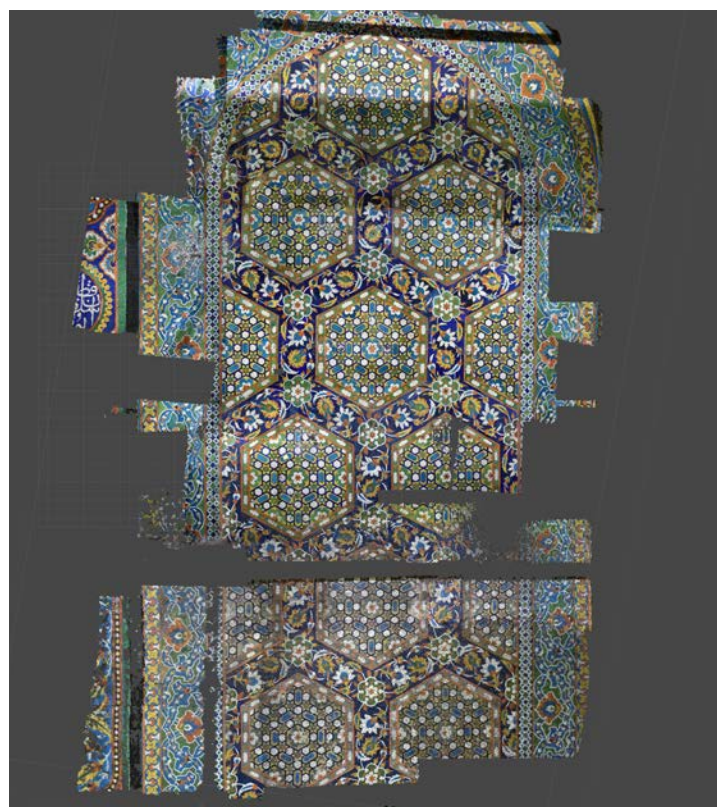

Photogrammetry is a scientific process documenting and taking measurements using a series of photographs. This helps build 3-d Models, 3 D point clouds and accurate measuring. The series of photos have been stitched together using a special software.



Removing paint layers to reveal the original enamelled tile underneath.

### **Documentation**

- Detailed documentation of tiles is being carried out to precisely estimate the extent of damage.
- Layers of 20<sup>th</sup> century paint obfuscating the underneath tiles are being revealed.
- The tiles are being individually traced and superimposed on AutoCAD drawings, prepared with perspective corrected photogrammetric images created using point cloud data.
- Thermal imaging cameras use infrared radiation to highlight areas beneath tiles with excessive water seepage in a rainbow coloured palette. This will aid in adopting an appropriate conservation methodology to conserve the tile embellishment on the internal facades.

### ***Action Taken:***

- Preliminary architectural of Badshahi Ashoorkhana, Naqarkhana and adjacent structures situated inside the precincts has been completed.
- Upon investigations on the terrace, it was found that cracks have appeared on the upper level of terrace resulting in seepage of rainwater inside the structure.
- Grouting of cracks on the upper terrace with a rich mix of lime mortar and organic additives was injected to seal and prevent future ingress of rainwater.
- Waterproofing was carried out on large patches adjacent to the outlets.
- Installation of 3 water spouts made in granite was carried out on the edge of the upper terrace to channel rainwater away from the main structure.
- Multiple structural cracks on the northern external wall were stitched using solid blocks of rubble stone and lime mortar. Rich lime mortar was injected into the crevices of cracks using injection grout carried out by experienced stonemasons.
- Flaked and loose lime mortar was carefully removed from the western external façade and repaired with rich lime mortar and finished with a 1 mm thin layer of lime putty mixed with organic additives.
- Projected plinth protection was constructed along the perimeter of the western wall to prevent the restored wall from vehicular traffic.

### ***Next Steps:***

- Removal of 20th-century cement concrete will be carried out and replaced with traditional lime concrete laid in an appropriate gradient to channel rainwater away from the structure.
- Documentation of tiles will commence. It will aid in assessing the extent of damage and help in adopting an appropriate conservation methodology.

### **Impact:**

Restoration of external walls and waterproofing have halted the water seepage from the terrace and mitigated immediate damage.





*His Excellency Hassan Rouhani, President of Islamic Republic of Iran visited the Mausoleum of Mohammed Quli Qutb Shah*



*His Excellency Muhammad Bakhtiyar Bin Wan Chik, the Deputy Minister of Tourism, Malaysia*



*Sri K.T.Rama Rao at the completion ceremony of Badi Baoli*



*Sri B.V.Papa Rao at the completion ceremony of Phase 1 works*

## 24 CONSERVATION AND LANDSCAPE RESTORATION Project Learnings

**Every year, the project collaborates with academic institutions, governmental agencies, cultural organizations, civil society, opinion makers, conservation professionals, students, bureaucrats and policymakers keen to learn from the experiences and interested to incorporate the successful aspects of the project in their work areas.**

Qutb Shahi Heritage Park has successfully demonstrated pilot for the revitalization of a historic palimpsest in a not-for-profit people-oriented public-private partnership model. The project has seamlessly integrated conservation of historic buildings with the landscape development and environmental up-gradation resulting in a better quality of life for the denizens.

**Nearly 204 visits have been conducted during 2017-18 as part of the project. The project team has conducted site walkthroughs for over 2130 state heads, diplomats, students, civil society members, bureaucrats, academia, corporate and organization teams from all over the world.**

# Sharing Project Learnings



Nearly 215 visits to the project area in 2017-2018





*Group of students at the lime workshop on site*

- Since the commencement of the project in 2013, the project team has conducted site walkthroughs for over 2130 of state heads, students, academia, civil society members, bureaucrats, corporate and organizational teams from across the globe.
- One significant visit was that of His Excellency Dr. Hassan Rouhani, President of the Islamic Republic of Iran who visited the project along with delegates on February 16, 2018. The delegates aimed to understand the partnership model between public and private institutions developed between AKTC and governmental agencies for successful implementation and management of the conservation coupled with landscape development.
- Students from Maulana Azad National Urdu University and the University of Hyderabad to understand the nuances of conservation and landscaping works being done and the linkage between heritage conservation and improving the quality of life for the visiting denizens
- Trainees at the All India Services Officer visited the project site to understand the project interventions in a public-private partnership of AKTC with multiple governmental agencies
- Students of Indian Hotel Management Institute visited the project site to understand the tourist visitor inflow, strategies used for upgrading visitor amenities and understand the engagement between visitors and a heritage site.
- A public undertaking Committee of the Member of Legislative Assembly and Members of Legislative Councils visited the project site to understand the conservation and development works being undertaken at city's prominent archaeological urban park.

“

*The concept of public-private partnership is an essential keystone for effective cultural development... The role of governments, including municipalities, is fundamental in providing what we often term “an enabling environment” for development.*

His Highness the Aga Khan



**Craftsmen at the Idgah**  
*At the Qutb Shahi Heritage Park, the team comprising lime plasterers, masons, stone carvers, gardeners and mistris have demonstrated a new model of craft-based approach to conservation of our heritage monuments and sites.*

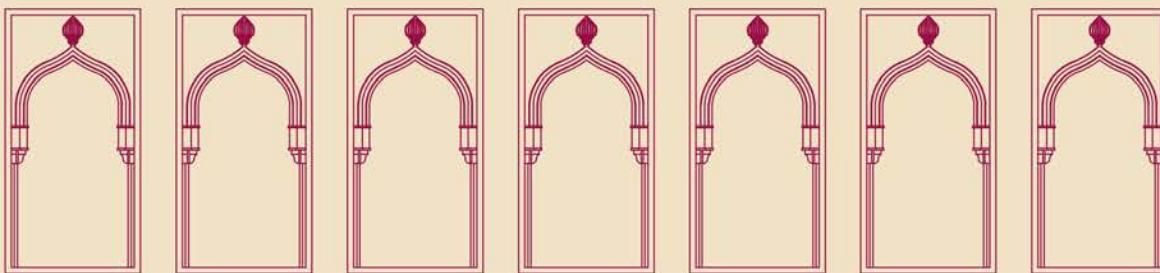



Mr. K T Rama Rao, Hon'ble Minister for Information and Technology, Municipal Administration & Urban Development, Govt. of Telangana at inauguration of Badi Baoli.



Ms. Visalatchy, Director, Heritage Telangana



Mr. Mohd. Ali, Deputy CM, Govt. of Telangana

On 9 January 2013, Government of Telangana's Department of Archaeology and Museums, the Greater Hyderabad Municipal Corporation's Quli Qutb Shah Urban Development Authority, Aga Khan Foundation and the Aga Khan Trust for Culture signed a MoU that, over a ten year period, will enable conservation of all 80 monuments and landscape restoration of the 106 acre Heritage Park.

Following the MoU, Tata Trusts have provided required funding for the conservation works on ten major monuments. The Ministry of Tourism, Government of India has pledged support for landscape works under the Swadesh Darshan scheme. Support has also been received from the US Ambassador's Fund for Cultural Preservation and the German Federal Foreign Office.

# Partners & Team

## Partner Agencies



HERITAGE TELANGANA  
GOVT. OF TELANGANA



QULI QUTB SHAH URBAN  
DEVELOPMENT AUTHORITY,  
HYDERABAD



AGA KHAN TRUST FOR CULTURE

## Supported by

**TATA TRUSTS**

FOR CONSERVATION WORKS  
ON TEN MAJOR MONUMENTS



US AMBASSADOR'S FUND  
FOR CULTURAL PRESERVATION

# PROJECT TEAM

## Public Agencies 2017-2018

### Government of Telengana

---

- Mr. Shailendra Kumar Joshi, IAS, Chief Secretary to Government, Government of Telangana.
- Mr. B. Venkatesham, IAS, Secretary, YAT&C, Government of Telangana.
- Mr. Arvind Kumar IAS, Principal Secretary to the Government Municipal Administration and Urban Development
- Mr. B.P. Acharya, IAS, Director General for MCR HRD Institute & Special Chief Secretary
- Mr. Navin Mittal, IAS, Commissioner Department of Information and Public Relations
- Mr. B Janardhan Reddy, IAS, Commissioner, GHMC, Government of Telangana
- Mrs. Sunita Bhagwat, IAS, Commissioner of Tourism Government of Telangana
- Mr. Md.Musharraf Ali Faruqui, IAS, Zonal Commissioner, GHMC, Government of Telangana



*Mr. B Venkatesham(IAS, Secretary, YAT&C, Government of Telangana) at the Qutb Shahi Heritage Park*

### Department of Archaeology & Museum, Govt. of Telengana

---

- Mrs. N.R. Visalatchy, IPoS, Director
- Mr. B. Narayana, Dy. Director, Engineering & I/c Director (Qutb Shahi Tombs)
- Mr. Md. Raheem Sha Ali, Deputy Director Engineering
- Mr. P. Bramahachari, Deputy Director Technical
- Dr. K. Padmanabha, Assistant Director Technical/Museums
- Mr. T.Ch. Nancharaiah, I/c Conservation Asst. (Qutb Shahi Tombs)
- Mr. A. Raju, Superintendent
- Mr. N. Narsingh, Conservation Assistant
- Mr. A. Balaraju, I/c Conservation Asst. (Qutb Shahi Tombs)  
Conservation Assistant



*Mr. Naveen Mittal(IAS, Commissioner Department of Information and Public Relations) at the Deccan Park*

### Project Technical Committee

- Mr. B. Venkatesham, IAS, Secretary, YAT&C, Government of Telangana.
- Mrs. Sunita M. Bhagwat, IFS, Commissioner of Tourism, Government of Telangana
- Mrs. N.R. Visalatchy, IPoS, Director, Department of Heritage Telangana, Government of Telangana
- Mohd. Raheem Sha Ali, Dy Director, Dept of Archaeology and Museums, Government of Telangana
- Mr. B. Narayana, Dy. Director, Department of Heritage Telangana, Government of Telangana
- Mr. A. Raju, Superintendent, Department of Heritage Telangana
- Dr. (Ms.). Christina Z Chongthu, IAS Managing Director, TSTDC
- Mr. Boinapally Manohar Managing Director, TSTDC
- Mrs. Saritha Galla, Executive Engineer, TSTDC
- Mr. A Ashok Kumar, Executive Engineer, TSTDC
- Mr. Srinivas Reddy, Asst. Executive Engineer, TSTDC
- Dr. M. Surender, General Manager, TSTDC
- Mr. Ch. Parsuvedi, Asst. Executive Engineer, TSTDC
- Mr. L. Kishan, Secretary, Quli Qutb Shah Urban Development Authority, Government of Telangana
- Mrs. Lalitha, Asst. Director (Horticulture), Quli Qutb Shah Urban Development Authority, Government of Telangana
- Mr. Sajjad Shahid, Independent Expert
- Mr. Emin Mahir Baleioglu, Director Museums, AKTC, Geneva
- Mr. Ratish Nanda, Chief Executive Officer, AKTC, New Delhi
- Mr. Yoshowant Purohit, Project Manager, AKTC, Hyderabad
- Mr. Ganesh Reddy, Manager Operations, AKTC, Hyderabad.
- Mr. Prashant Banerjee, Program Officer - Conservation, AKTC, Hyderabad.

### Greater Hyderabad Municipal Corporation

- Mr. B Janardhan Reddy, IAS, Commissioner
- Mr. M Dana Kishore, IAS, Commissioner
- Mr. Md.Musharraf Ali Faruqui, IAS, Zonal Commissioner
- Mr. S. Devender Reddy, Chief City Planner
- Mr. Srinivas Rao, Additional Chief City Planner & Director, Heritage wing
- Mr. Pradeep Reddy, Executive Engineer
- Mr. Lachiram, Executive Engineer
- Mr. Venkat Reddy, Asst. Engineer
- Mr. Khalil Sarvar, City Planner

## Quli Qutub Shah Urban Development Authority

- Mr. B Janardhan Reddy, IAS, Administrator
- Mr. M Dana Kishore, IAS, Administrator
- Mr. L.Kishan, Secretary
- Mrs. M. Lalitha, Assistant Director of Horticulture

## Telangana State Tourism Development Corporation

- Dr. (Ms.). Christina Z Chongthu, IAS Managing Director
- Mr. Boinapally Manohar, Managing Director
- Mr. N. Ganga Reddy, Superintending Engineer
- Mr. K. Kranthi Babu, Superintending Engineer
- Mr. Ashoka Kumar, Executive Engineer
- Mrs. Saritha Galla, Executive Engineer
- Mr. Ch. Parshavedi, Assistant Executive Engineer
- Mr. Vinod Kumar, Assistant Executive Engineer

## Mandal Revenue Office

- Mr. Venkat Reddy, MRO, Shaikpet Mandal
- Mr. Mahendar Reddy, MRO, Golconda Mandal
- Mrs. Chandra Kala, MRO, Shaikpet Mandal
- Mrs. Sujatha , MRO, Shaikpet Mandal
- Mr. V Vamshimohan, MRO, Golconda Mandal

## Salar Jung Museum

- Mr. Nagendra Reddy, Director
- Mr. Veerender Reddy, Dy. Keeper



*Mr. B Janardhan Reddy with by Mr.Chandra Mohan, and L Kishan, Secretary, Quli Qutub Shah Urban Development Authority along with other delegates*

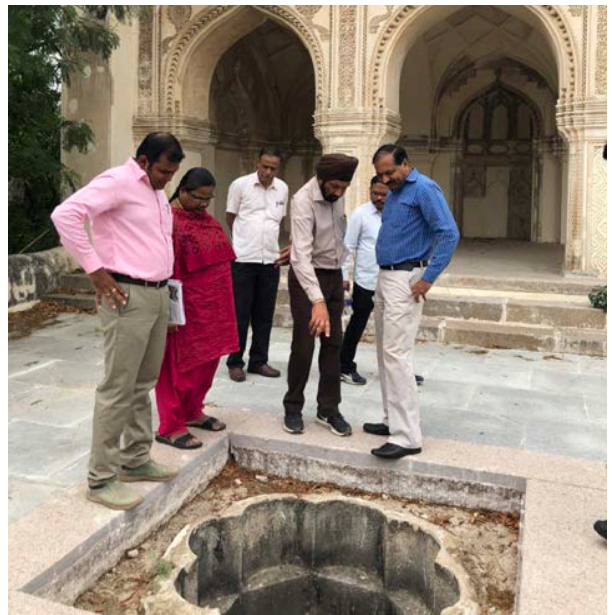

*Mr. B. Manohar(Managing Director, TSTDC) and Mrs. Saritha Galla(Executive Engineer, TSTDC) at Qutb Shahi Heritage Park*

# PROJECT TEAM

## Qutb Shahi Heritage Park, Hyderabad

### Aga Khan Trust for Culture

---

- Mr. Ratish Nanda, CEO
- Mr. Rajpal Singh, Chief Engineer
- Ms. Jyotsna Lall, Senior Programme Officer
- Mr. Yoshowant Purohit, Project Manager
- Mr. K. Ganesh Reddy, Manager Operations
- Mr. Prashant Banerjee, Program Officer - Conservation
- Ms. Archana S Akhtar, Sr. Program Officer, Design & Outreach
- Mr. Somak Ghosh, Finance Manager
- Mr. Deepak Padhi, Program Officer, Monitoring & Evaluation
- Ms. Shveta Mathur, Program Officer, Urban Planning
- Mr. KP Singh, Chief Horticulturist
- Ms. Nitya Khendry, Architect
- Ms. Neha Tambe, Conservation Architect
- Ms. Natasha Khaitan, Architect
- Mr. Ziauddin Malik, Project Engineer
- Mr. Faneendra Nath, Consultant, Project Engineer
- Mr. Arshad Jamil, Consultant, Site Engineer
- Mr. Shaik Irfan Siddique, Consultant, Site Engineer
- Ms. V. Sridevi, Finance Officer
- Ms. Lipi Bharadwaj, Project Photographer
- Mr. Rajendra Patnaik, Office Secretary
- Mr. Vinod Kumar, Field Supervisor
- Mr. Izhar Ahmed, Field Supervisor
- Mr. Ashok Kumar, Supervisor
- Mr. P Srinu, Consultant - Field Supervisor
- Mr. M. Rajesh, Office Chauffeur

### Principal Consultants

---

- Shaheer Associates, Landscape Architect
- Mr. Sajjad Shahid, Advisor, Consultant
- Ms. Poornima Balakrishnan, Consultant – Conservation Architect
- Mr. Shafeeq Rehman Mahajir, Legal Consultant, Brainstorm Legal Advocates
- Geotechnics Engineering Solutions–3D Scan Consultants
- Mr. Sree Rama, Lantek Engineering Consultants
- Mr. Vivekananda Kalepu, Video Consultant









For internal circulation only.  
Copyright: AKTC; All rights reserved.  
*All photographs used in the report have been taken by the AKTC project team.*